

KOMATSU®

WA200-6

WA
200

HORSEPOWER

Gross: 95.2 kW 128 HP / 2000 min⁻¹

Net: 94 kW 126 HP / 2000 min⁻¹

OPERATING WEIGHT

9635 – 10250 kg

BUCKET CAPACITY

1.6 – 2.4 m³



Photos may include optional equipment.

WALK-AROUND



ecot3
ecology & economy - technology 3



WA200-6

HORSEPOWER	Gross: 95.2 kW 128 HP / 2000 min ⁻¹
	Net: 94 kW 126 HP / 2000 min ⁻¹
OPERATING WEIGHT	9635 – 10250 kg
BUCKET CAPACITY	1.6 – 2.4 m ³

HIGH PRODUCTIVITY & LOW FUEL CONSUMPTION

- Faster Travel & Lower Fuel Consumption
- Highly Efficient Hydrostatic Transmission (HST)
- Electronically-controlled HST with Variable Shift Control System
- Useful Functions Given by HST
- Variable Traction Control System
- Maximum Dumping Clearance and Reach

INCREASED RELIABILITY

- Komatsu Components
- High-rigidity Frames and Loader Linkage
- Wet Multiple-disc Brakes and Fully Hydraulic Braking System

EXCELLENT OPERATOR ENVIRONMENT

- Pillar-less Large Cab
- Great Rear Visibility
- Best Position for Comfort
- Easy-to-operate Loader Control Mono-lever

EASY MAINTENANCE

- Maintenance Accessibility
- Protective Guards
- Equipment Management Monitoring System
- Easy Radiator Cleaning

SAFETY

- ROPS/FOPS Cab (ISO 3471/ISO 3449)
- Rear-hinged Full Open Cab Door

KOMTRAX

- KOMTRAX

HIGH PRODUCTIVITY & LOW FUEL CONSUMPTION



Faster Travel & Lower Fuel Consumption

High performance SAA4D107E-1 engine

Electronic heavy duty common rail fuel injection system provides optimum combustion of fuel. This system also provides fast throttle response to match the machine's powerful tractive effort and fast hydraulic response.

Net: 94 kW 126 HP

Low emission engine

This engine is U.S. EPA Tier 3 and EU Stage 3A emissions certified, without sacrificing power or machine productivity.

Low fuel consumption

The high-torque engine and HST with maximum efficiency in the low-speed range provide low fuel consumption.

ECO indicator

The ECO indicator will inform the operator when the machine is maximizing fuel efficiency.



ECO indicator



Highly Efficient HST

Electronically-controlled HST with a variable pump and 2-motor system

Komatsu HST system allow a highly efficient and powerful operation. Increasing pump capacity and variable input torque control of new electronically controlled HST pump enable the engine to run at the best speed range and reduce fuel consumption.

The efficiency of HST motors

HST provides quick travel response and aggressive drive into the pile. The variable displacement system automatically adjusts to the tractive effort demand to provide maximum power and efficiency. When high drive torque is needed, both motors are engaged to provide highest torque. Maximum rim pull can provided from zero travel speed. This combination makes the loader very aggressive and quick at digging, climbing or initiating movement. When high travel speed is needed, clutch cuts off the low speed motor to eliminate drag and achieve excellent fuel efficiency.

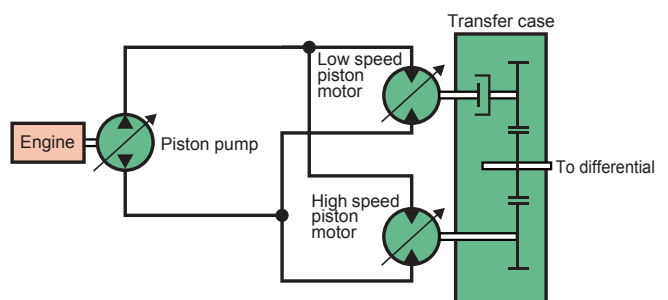

Electronically-controlled HST with Variable Shift Control System

Full auto-shifting

Full auto shifting eliminates any gear shifting and kick-down operation to allow the operator to concentrate on digging and loading.

Variable shift control system

The variable shift control system allows setting the top speed for increased safety and precision. The operator can choose between first, second, third or fourth maximum speeds by dialing the speed range selector switch. For v-cycles, the operator can set the speed control switch to 1 or 2, which provides aggressive digging, quick response and fast hydraulics. For load and carry, select 3 or 4 which still provides aggressive digging but with much faster travel speed.

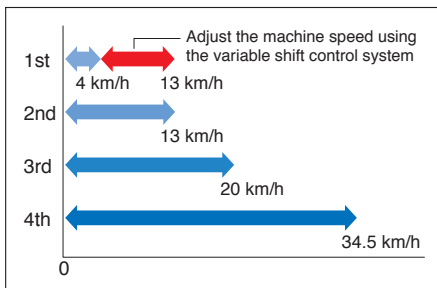

Variable and fine travel speed control

When the variable shift control switch is in 1st speed, ground speed can be adjusted between 4 km/h and 13 km/h with the fine control. This allows constant low driving speeds that are perfectly adjusted to applications such as lawn mowing or milling jobs.

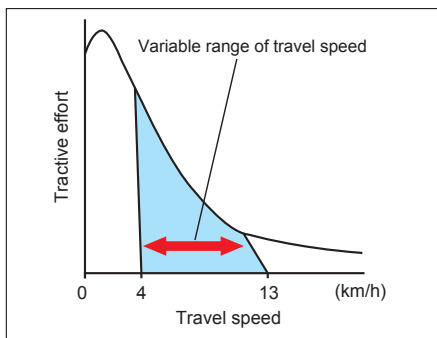

- ① Speed range selector switch
- ② Variable shift control switch

Useful Functions Given by HST

Self braking effect of the HST drive lines

The self braking effect of the HST drive line slows down the machine when the accelerator pedal is released. It can hold the loader in position on workable slopes, and it will be an advantage in stockpiling or ramp loading. Also it prevents uncontrolled rolling. Safety is greatly improved especially when working in confined spaces or inside industrial buildings. In addition, brake wear is practically eliminated.

Improved inching performance

Electronically controlled HST brake provides improved inching performance of the machine and demonstrates ideal braking control when the machine is travelling and working.

Accelerator pedal sensitive intelligent HST control

Finely-tuned HST control according to the accelerator pedal angle achieves variable clutch timing by machine speed and motor shift control in quick acceleration. It reduces shocks and allows smoother traveling and better energy-saving operation.



Overrun prevention system

Overrun prevention system will secure safety in downhill and protect the power train and brake components from overload. When the travel speed reaches 36 km/h, the caution lamp informs the operator to reduce the speed. When the machine descends a moderate slope (6 degrees or less), maximum travel speed is automatically limited to 38 km/h.

Notes: When the machine descends a steep slope, it is necessary to use the service brake to reduce the speed for safety.



Variable Traction Control System

The variable traction control system optimizes the digging traction automatically depending on working condition by controlling HST pump, motor and engine. Combined with the function of torque proportioning differentials, or optional limited slip differential this system exerts the following effects.

- Facilitates operation on soft ground where the tires of the machine are apt to slip.
- Eliminates excessive bucket penetration and reduces tire slippage during stockpile loading to improve the work efficiency.
- Reduces tire slippage to extend the life of tires. Furthermore, the maximum tractive effort can be adjusted in five stages while the traction control switch is ON. This allows the operator to select the optimum tractive effort for diversified road conditions.

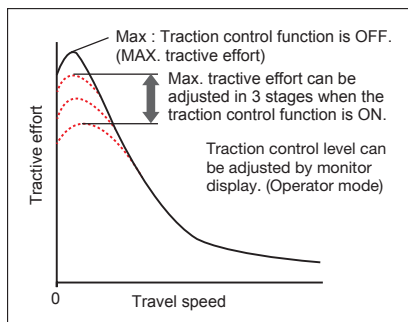

Traction control OFF (MAX) position

Traction control ON position

S-mode position



S-mode

Setting the switch to S-mode allows the machine to get the optimum driving force for operations on slippery road surfaces, like snow-removal on snow surface, resulting in reduced tire slippage and facilitation of the operation. Unexpected tire slippage on slippery road surface is suppressed by controlling the engine speed and HST motor when traveling at a low speed. (S-mode is effective only in forward traveling.)

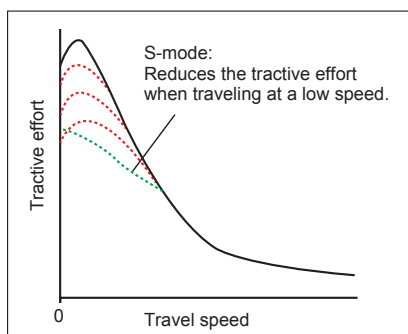

Max. traction switch

Max. traction switch is located on the work equipment control lever. When traction control switch is at ON position or S-mode is selected, pushing this switch cancels the setting of the traction control temporarily and increases the tractive effort to its 100% value. Then pushing the max. traction switch again or operating the F/R lever returns the tractive effort to the set value automatically. This switch is useful for operations such as piling up work where large tractive effort is required temporarily.

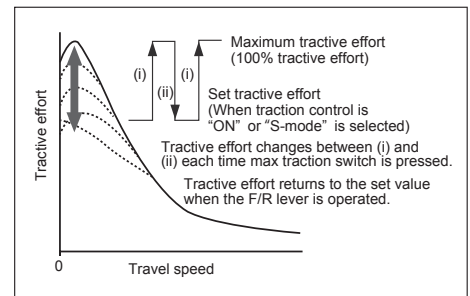

Max. traction switch



Maximum Dumping Clearance and Reach

The long lift arms provide high dumping clearances and maximum dumping reach. The operator can even level loads on the body of a dump truck easily and efficiently.

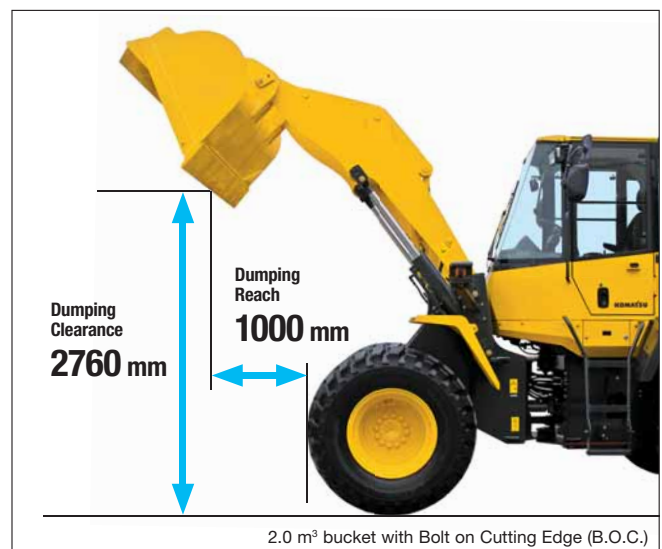

INCREASED RELIABILITY

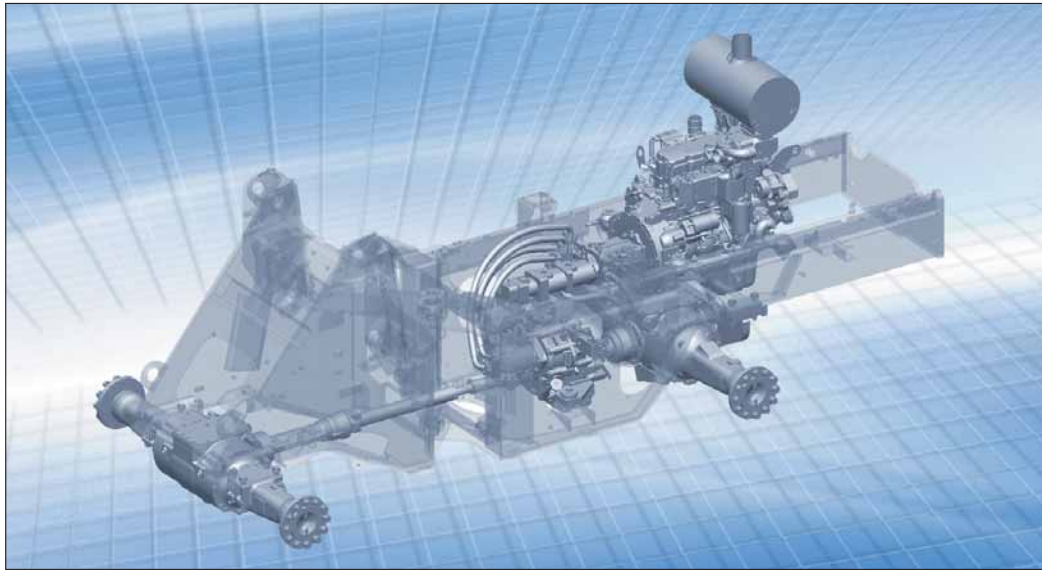

Komatsu Components

Komatsu manufactures the engine, transfer case and hydraulic components on this wheel loader. Komatsu loaders are manufactured with an integrated production system under a strict quality control system.

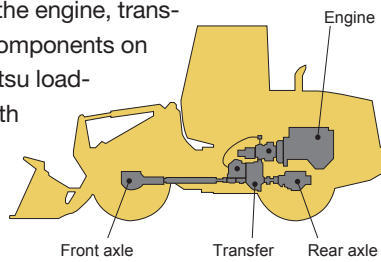

Wet Multiple-disc Brakes and Fully Hydraulic Braking System

This system result in lower maintenance costs and higher reliability. Wet multiple-disc brakes are fully sealed. Contaminants are kept out, reducing wear and resulting maintenance. Brakes require no adjustments for wear, meaning even lower maintenance. The parking brake is also an adjustment-free, wet multiple-disc for high reliability and long life. Added reliability is designed into the braking system by the use of two independent hydraulic circuits. Provides hydraulic backup should one of the circuits fail.

Fully hydraulic brakes mean no air system to bleed, or the condensation of water in the system that can lead to contamination, corrosion, and freezing.

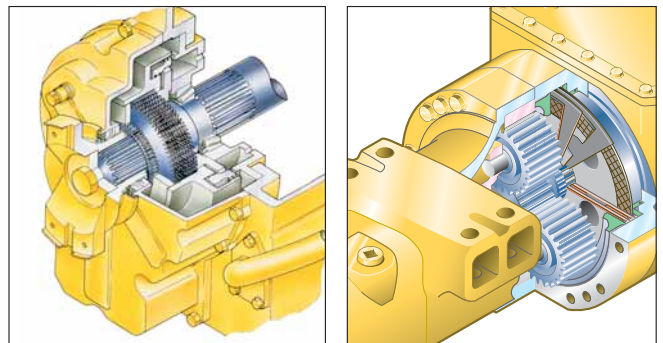

High-rigidity Frames and Loader Linkage

The front and rear frames and the loader linkage have got more torsional rigidity to provide resistance increased to stresses. Frame and loader linkage are designed to accommodate actual working loads, and simulated computer testing proves its strength.

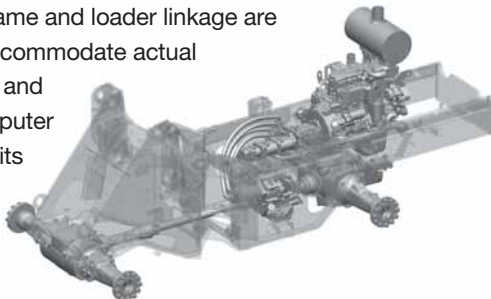

Sealed Connectors

Main harnesses and controller connectors are equipped with sealed connectors providing high reliability, water resistance and dust resistance.



Reliable Hydraulic Line

Flat face-to-face O-ring seals
Flat face-to-face O-ring seals are used to securely seal hydraulic hose connections and to prevent oil leakage.

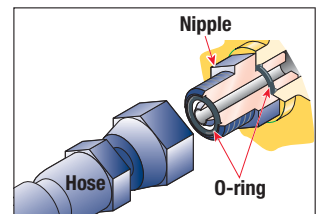

EXCELLENT OPERATOR ENVIRONMENT



The large space cab offers exceptional driver's comfort - comparable to a passenger car. The large, frameless window gives an unobstructed view of the bucket and tires while the slanted rear end ensures a clear view to the rear. The low-noise designed cab with the air-cushioned seat and the fully adjustable console inside allow the operator to work comfortably and productively over long period.

Pillar-less Large Cab

A wide pillar-less flat glass provides excellent front visibility. The wiper arm covers a large area to provide great visibility even on rainy days. The large cab area providing maximum space for the operator. The front mounted air conditioner (A/C) was introduced to increase seat reclining and backward slide adjustment.



Great Rear Visibility

Center lined muffler and air intake piping provides great rear right and left hand side visibility.



Best Position for Comfort

Tiltable steering column

The operator can tilt the steering column to provide a comfortable working position.



Adjustable wrist rest

The height of wrist rest is adjustable. It allows operators to adjust the controls to a comfortable position.



Low-noise Design

The large cab is mounted with Komatsu's unique ROPS/FOPS (ISO 3471/ISO 3449) viscous mounts. The low-noise engine, hydraulically driven fan, and hydraulic pumps are mounted with rubber cushions, and the cab sealing is improved to provide a quiet, low-vibration, dustproof with pressurizing, and comfortable operating environment.

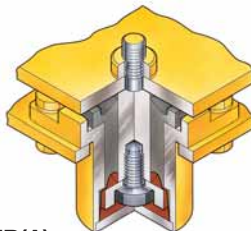

Operator's ear noise level: 70 dB(A)
Dynamic noise level (Outside): 104 dB(A)

Electronically Controlled Directional Lever

The operator can change direction with a touch of his fingers without removing his hand from the steering wheel. Solid state electronics makes this possible.



Easy-to-operate Loader Control Mono-lever

The new mono-lever using Proportional Pressure Control (PPC) allows the operator to easily operate the work equipment, to reduce operator fatigue and to increase controllability. The adjustable wrist rest provides the operator with a variety of comfortable operating positions.

Right-side Control Panel

The operator can easily select the speed range, maximum travel speed in 1st, tractive effort.



- 1 Loader control mono-lever
- 2 Speed range selector switch
- 3 Variable shift control switch
- 4 Traction control switch
- 5 Max. traction switch
- 6 Fan reverse switch

Options

12 V outlet

In addition to 24 V cigarette lighter, 12 V outlet is provided in the cab.

Electronically Controlled Suspension System

Electronically Controlled Suspension System uses an accumulator which absorbs some of the shock in the boom arm, giving the operator a much smoother ride. This reduces operator fatigue and reduces material spillage during load and carry operations. Electronically Controlled Suspension System operation is speed sensitive and turned off automatically below 5 km/h speed, meaning that the boom won't move during stationary digging.

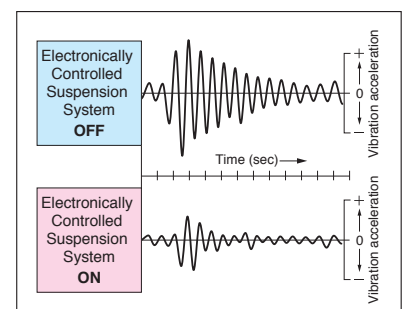

* Image is for illustration purpose

EASY MAINTENANCE



Gull-wing side doors upper locked position



Gull-wing side doors lower locked position

Maintenance Accessibility

Designed to save time

With long service intervals and best-in-class accessibility, the WA200-6 reduces the time and money you need to spend on maintenance. A gas spring helps the operator open and close each gull-wing side door for easy daily servicing. The doors open in two steps and be able to use upper or lower stop position as the situation demands.

Simple and convenient access to service

The service doors are designed as gull-wing doors. They allow you convenient and safe access to the daily service points from the ground.



Protective Guards

Thermal safety guards

Thermal guards for high temperature exhaust manifold are installed.



Rotating safety guards

Protective guards for rotating parts of the alternator and the air conditioner compressor are installed.



Equipment Management Monitoring System

Komatsu's new main monitor keeps the operator informed of all machine functions at a glance. The monitor is located behind the steering wheel and displays different machine functions including fluid/filter change intervals and troubleshooting memory display functions. The main gauges are analog type for easy viewing and other functions utilize lighted symbols or Liquid Crystal Display (LCD) readouts.

Maintenance control and troubleshooting functions

- **Action code display function:** If an abnormality occurs, the monitor displays action details on the character display at the bottom center of the monitor.
- **Monitor function:** Controller monitors engine oil level, pressure, coolant temperature, air cleaner clogging, etc. If controller finds abnormalities, the error is displayed on LCD.
- **Replacement time notice function:** Monitor informs replacement time of oil and filters on LCD when replacement intervals are reached.
- **Trouble data memory function:** Monitor stores abnormalities for effective troubleshooting.



- 1 Engine coolant temperature
- 2 Speedometer
- 3 Fuel gauge
- 4 HST oil temperature gauge
- 5 Character display
- 6 Inspection and maintenance items pilot lamp

Easy Radiator Cleaning

Hydraulic driven fan with reverse rotation

If the machine is operating in adverse conditions, the operator can reverse the hydraulic cooling fan from inside the cab by pressing a switch on the control panel.

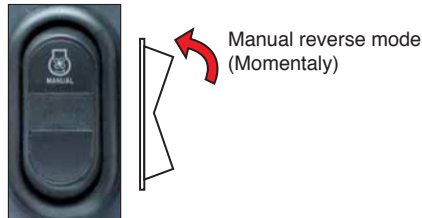

Automatic reversible fan (Optional)

The engine fan is driven hydraulically and can be operated in reverse automatically. When the switch is in the automatic position, the fan revolves in reverse for 2 minutes every 2 hours intermittently (Default setting).

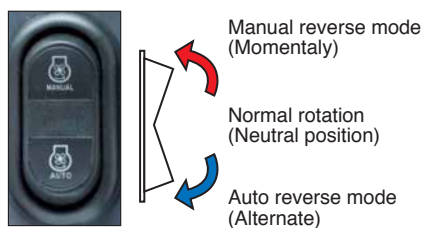

Hydraulic driven fan

Side-by-side cooling unit

The cooling system is isolated from the engine by a bulkhead to provide more efficient cooling and low noise. The radiator, air-to-air cooler and oil cooler are mounted side-by-side for more efficient cooling and easy cleaning. A fully-opening, gas spring assisted rear grille gives the operator excellent access to the swing-out fan and coolers.



Swing-out fan

Side-by-side cooling unit



ROPS/FOPS Cab

The ROPS/FOPS cab is standard for operator's safety. A wide pillar-less flat glass provides excellent front visibility, and a heated rear window provides excellent rear visibility in cold and freezing weather conditions.

ROPS (ISO 3471) : Roll-over Protective Structure

FOPS (ISO 3449) : Falling Objects Protective Structure



Alternate Exit of Cab

The door on the right side of the cab is provided as an alternate exit for use when the operator cannot get out through the door on the left side.

Other Safety Features

Two independent lines brake system

Added reliability is designed into the braking system by the use of two independent hydraulic circuits, providing hydraulic backup should one of the circuits fail.

Secondary steering (Optional)

If the steering pump is disabled, a secondary steering pump provides hydraulic flow.

Battery disconnect switch (Optional)

The battery disconnect switch is located in the right side battery box. This can be used to disconnect power when performing service work on the machine.

Rear-hinged Full Open Cab Door

The cab door hinges are installed to the rear side of the cab providing a large opening angle for the operator to enter and exit. The steps are designed like a staircase, so that the operator can get on and off the cab easily.



KOMTRAX

The Komatsu remote monitoring and management technology provides insightful data about your equipment and fleet in user-friendly format.

Energy Saving Operation Report

KOMTRAX delivers the energy-saving operation report based on the operating information such as fuel consumption, load summary and idling time, which helps you efficiently run a business.



This report image is an example of hydraulic excavator

Equipment Management Support

Through the web application, a variety of search parameters are available to quickly find information about specific machines based on key factors. Moreover, KOMTRAX finds out machines with problems from your fleet and shows you through an optimal interface.

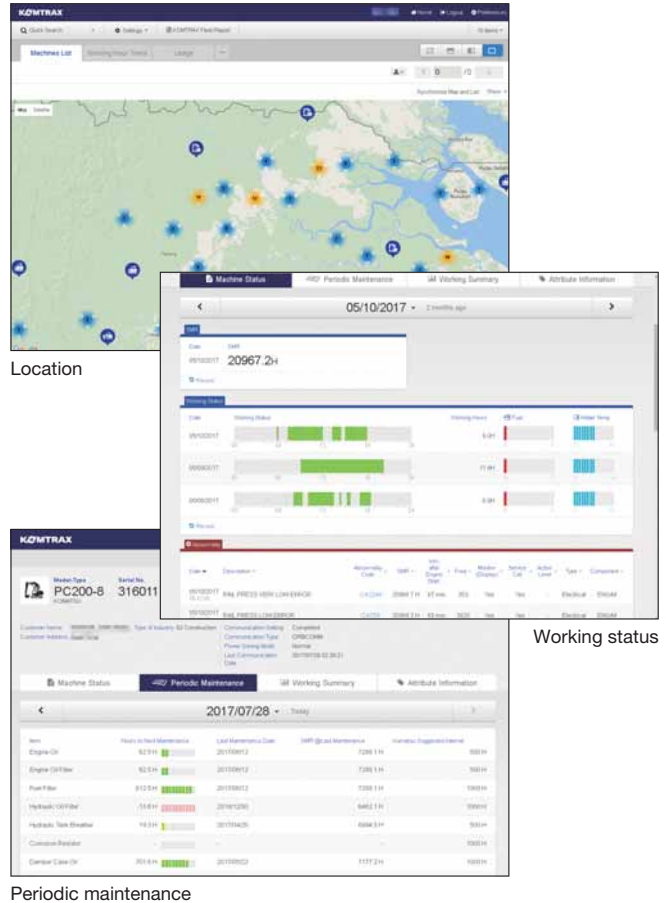

Location

Working status

Periodic maintenance

The report contents and data depend on the machine model.

Optimal Strategy for Efficient Work

The detailed information that KOMTRAX puts at your fingertips helps you manage your fleet conveniently on the web anytime, anywhere. It gives you the power to make better daily and long-term strategic decisions.



SPECIFICATIONS



ENGINE

Model Komatsu SAA4D107E-1
 Type..... Water-cooled, 4-cycle
 Aspiration Turbocharged, aftercooled
 Number of cylinders4
 Bore x stroke..... 107 mm x 124 mm
 Piston displacement4.46 L
 Governor All-speed, electronic
 Horsepower
 SAE J1995 Gross 95.2 kW 128 HP
 ISO 9249/SAE J1349*Net 94 kW 126 HP
 Rated rpm..... 2000 min⁻¹
 Fan drive method for radiator cooling Hydraulic
 Fuel system.....Direct injection
 Lubrication system:
 Method Gear pump, force-lubrication
 Filter Full-flow type
 Air cleaner Dry type with double elements and
 dust evacuator, plus dust indicator

* Net horsepower at the maximum speed of radiator cooling fan is 91 kW
 122 HP.
 U.S. EPA Tier 3 and EU Stage 3A emissions certified.



TRANSMISSION

Transmission:
 Type . . . Hydrostatic, 1 pump, 2 motors with speed range select
 Travel speed:
 Measured with 17.5-25 tires

	1st	2nd	3rd	4th
Both Forward and Reverse	4.0 - 13.0 km/h	13.0 km/h	20.0 km/h	34.5 km/h

Measured with 20.5-25 tires

	1st	2nd	3rd	4th
Both Forward and Reverse	4.4 - 14.3 km/h	14.3 km/h	22.0 km/h	38.0 km/h



AXLES AND FINAL DRIVES

Drive system Four-wheel drive
 FrontFixed, semi-floating
 Rear.....Center-pin support, semi-floating,
 24° total oscillation
 Reduction gear Spiral bevel gear
 Differential gear.....Torque proportioning
 Final reduction gear Planetary gear, single reduction



BRAKES

Service brakes..... Hydraulically actuated,
 wet multiple-disc brakes actuate on four wheels
 Parking brake . . .Wet, multiple-disc brake on transfer output shaft
 Secondary brake..... Parking brake is commonly used



STEERING SYSTEM

Type..... Full-hydraulic power steering
 Steering angle.....38° each direction (40° end stop)
 Minimum turning radius at the center of outside tire 5100 mm



HYDRAULIC SYSTEM

Steering system:
 Hydraulic pump Gear type pump
 Capacity 85 L/min at rated rpm
 Relief valve setting20.6 MPa 210 kgf/cm²
 Hydraulic cylinders:
 Type Double-acting, piston type
 Number of cylinders.....2
 Bore x stroke 70 mm x 453 mm
 Loader control:
 Hydraulic pump Gear type pump
 Capacity54 L/min
 Relief valve setting20.6 MPa 210 kgf/cm²
 Hydraulic cylinders:
 Type Double-acting, piston type
 Number of cylinders-bore x stroke:
 Lift cylinder2- 120 mm x 673.5 mm
 Bucket cylinder 1- 130 mm x 493 mm
 Control valve..... 2-spool type
 Control positions:
 Boom Raise, hold, lower, and float
 Bucket Tilt-back, hold, and dump
 Hydraulic cycle time (Rated load in bucket)
 Raise.....5.9 s
 Dump1.4 s
 Lower (Empty)3.6 s



SERVICE REFILL CAPACITIES

Cooling system 17 L
 Fuel tank 177 L
 Engine15.5 L
 Hydraulic system..... 58 L
 Axle (Each front and rear) 18 L
 Torque converter and transmission 5 L



DIMENSIONS

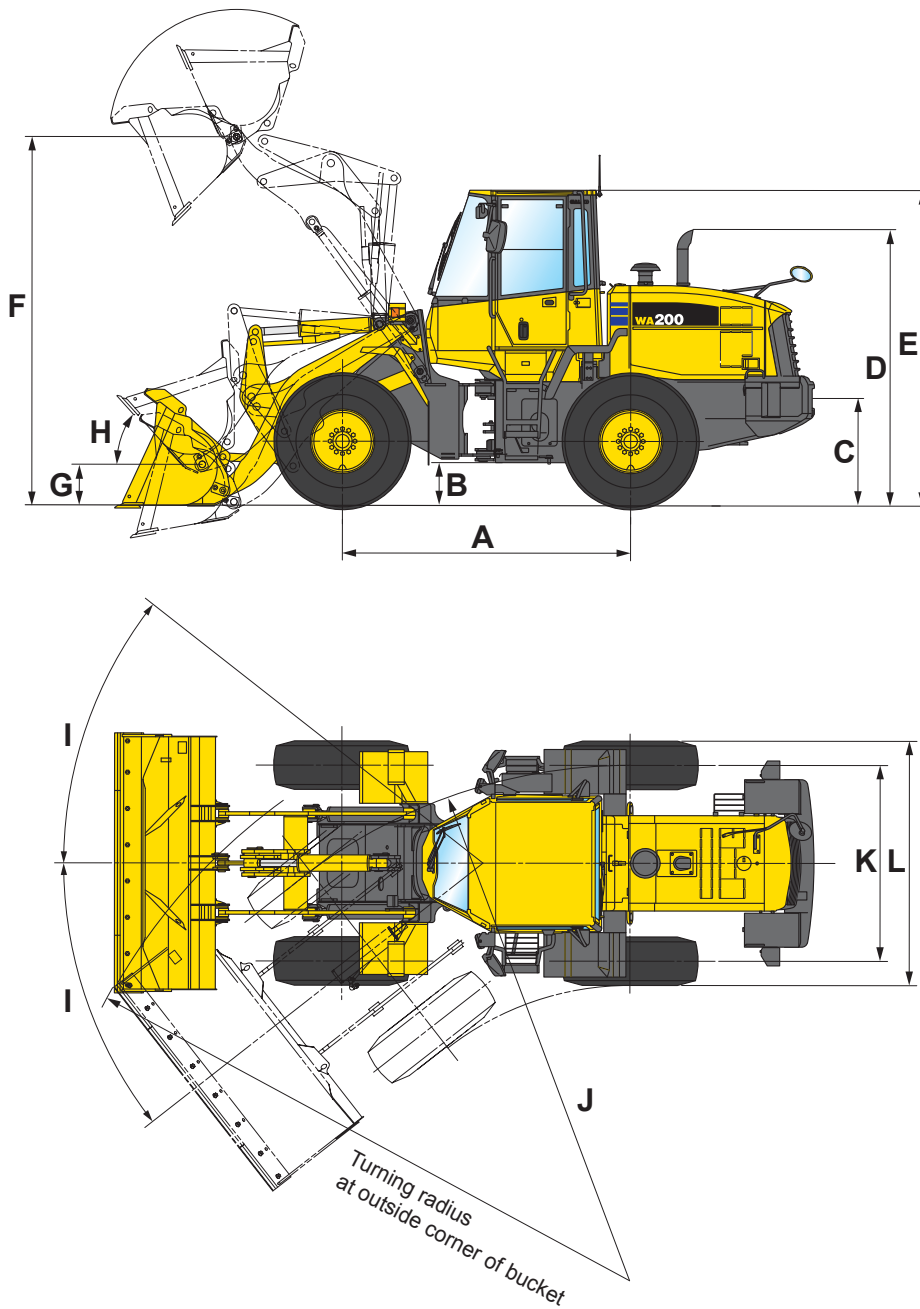

Measured with 17.5-25-12PR (L-3) tires

	Standard Boom	High Lift Boom
A Wheelbase	2840 mm	
B Ground clearance	425 mm	
C Hitch height	870 mm	
D Overall height, top of stack	2725 mm	
E Overall height, top of ROPS cab	3110 mm	
F Hinge pin height, max. height	3635 mm	4320 mm
G Hinge pin height, carry position	410 mm	600 mm
H Max. tilt back angle, carry position	48°	50°
I Steering angle, each direction	38°	
J Turning radius, center of outside tire	5100 mm	
K Tread	1930 mm	
L Width over tires	2375 mm	



DIMENSIONS

Measured with 17.5-25-12PR (L-3) tires

		Standard Boom				
		Stockpile Bucket		Excavating Bucket		Light Material Bucket
		B.O.C. ^{*2}	Teeth	B.O.C. ^{*2}	Teeth	B.O.C. ^{*2}
Bucket Capacity:	Heaped	2.0 m ³	1.9 m ³	1.7 m ³	1.6 m ³	2.4 m ³
	Struck	1.7 m ³	1.6 m ³	1.4 m ³	1.3 m ³	2.0 m ³
Bucket Width		2550 mm	2565 mm	2550 mm	2565 mm	2550 mm
Bucket Weight		785 kg	730 kg	740 kg	685 kg	875 kg
Dumping Clearance, Max. Height and 45° Dump Angle ¹		2760 mm	2670 mm	2815 mm	2730 mm	2655 mm
Reach at Max. Height and 45° Dump Angle ¹		1000 mm	1075 mm	945 mm	1015 mm	1105 mm
Reach at 2130 mm Clearance and 45° Dump Angle		1480 mm	1505 mm	1455 mm	1480 mm	1530 mm
Reach with Arm Horizontal and Bucket Level		2215 mm	2330 mm	2135 mm	2245 mm	2365 mm
Operating Height (Fully Raised)		4885 mm	4885 mm	4765 mm	4765 mm	4995 mm
Overall Length		6895 mm	7010 mm	6815 mm	6930 mm	7045 mm
Loader Clearance Circle (Bucket at Carry, Outside Corner of Bucket)		11700 mm	11780 mm	11660 mm	11740 mm	11780 mm
Digging Depth:	0°	140 mm	150 mm	140 mm	150 mm	140 mm
	10°	320 mm	350 mm	305 mm	335 mm	345 mm
Static Tipping Load:	Straight	8735 kg	8785 kg	8795 kg	8830 kg	8585 kg
	40° Full Turn	7515 kg	7555 kg	7575 kg	7595 kg	7365 kg
Breakout Force		9500 kg	8465 kg	10450 kg	9245 kg	8300 kg
Operating Weight		9735 kg	9680 kg	9690 kg	9635 kg	9820 kg

		High Lift Boom	
		Excavating Bucket	
		B.O.C. ^{*2}	Teeth
Bucket Capacity:	Heaped	1.7 m ³	1.6 m ³
	Struck	1.4 m ³	1.3 m ³
Bucket Width		2550 mm	2565 mm
Bucket Weight		740 kg	685 kg
Dumping Clearance, Max. Height and 45° Dump Angle ¹		3410 mm	3325 mm
Reach at Max. Height and 45° Dump Angle ¹		1035 mm	1110 mm
Reach at 2130 mm Clearance and 45° Dump Angle		2020 mm	2055 mm
Reach with Arm Horizontal and Bucket Level		2650 mm	2760 mm
Operating Height (Fully Raised)		5360 mm	5360 mm
Overall Length		7465 mm	7580 mm
Loader Clearance Circle (Bucket at Carry, Outside Corner of Bucket)		12220 mm	12310 mm
Digging Depth:	0°	270 mm	280 mm
	10°	435 mm	465 mm
Static Tipping Load:	Straight	6960 kg	7030 kg
	40° Full Turn	5985 kg	6045 kg
Breakout Force		9545 kg	8445 kg
Operating Weight		10250 kg	10195 kg

*1 At the end of tooth or Bolt on Cutting Edge (B.O.C.).

All dimensions, weights, and performance values based on SAE J732c and J742b standards.

Static tipping load and operating weight shown include lubricant, coolant, full fuel tank, ROPS cab, and operator. Machine stability and operating weight affected by counterweight, tire size, and other attachments. Apply the following weight changes to operating weight and static tipping load.

*2 Bolt on Cutting Edges



BUCKET SELECTION GUIDE

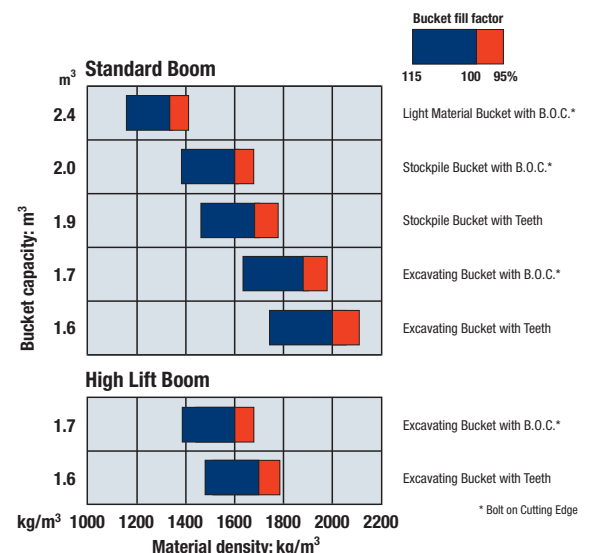



BUCKETS & ATTACHMENTS

■ Buckets

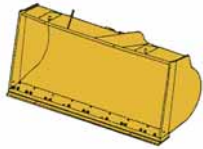
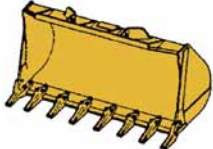
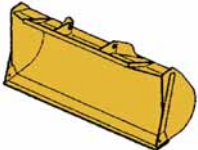
Type	Feature	Image
Stockpile Bucket	This bucket is used for loading stockpile products, such as crushed rock and construction materials.	
Excavating Bucket	This bucket is used for excavating and loading blasted rock on rock crushing job sites, or for excavating natural ground. It has a flat-blade, straight cutting edge, and provides superior rigidity and wear resistance.	
Loose/Light Material Bucket	This bucket is used for loading materials with comparatively light specific gravity. It is based on the stockpile bucket, with a lengthened cutting edge and width to give increased capacity.	

■ Cutting Edges and Teeth

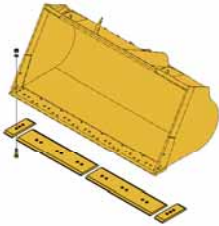
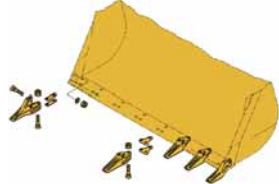
Type	Feature	Image
Cutting Edges	This edge is made for use in loading loose sand and soil, or for loading stockpiled materials. It is bolted to the leading edge of stockpile buckets and may be detached and reversed. The cutting edges are manufactured from especially heat treated, high tension steel, and since they are reversible, both edges can be used. This effectively doubles their working life.	<p>Bolt on Cutting Edges (B.O.C.)</p> 
Teeth (Bolt on Type)	These teeth are suitable for loading or excavation of piles of earth or sand, blasted rock, and jobs in the field that involve digging into the side of slopes. The special heat treated, tensile strength steel alloy used in their production assures that they will wear and have a long service life.	



WEIGHT / DIMENSIONS

Tires/Attachments	Change in Operating Weight	Change in Tipping Load Straight	Change in Tipping Load Full Turn	Width Over Tires	Ground Clearance	Change in Vertical Dimensions
17.5-25-12PR (L-3)	0 kg	0 kg	0 kg	2375 mm	425 mm	0 mm
17.5-25-12PR (L-2)	-105 kg	-80 kg	-70 kg	2375 mm	425 mm	0 mm
20.5-25-12PR (L-3)	480 kg	365 kg	320 kg	2470 mm	495 mm	70 mm
20.5-25-12PR (L-2)	295 kg	225 kg	200 kg	2470 mm	495 mm	70 mm
Install ROPS (ISO 3471) Canopy (Instead of Cab)	-255 kg	-230 kg	-200 kg			
Install Additional Counterweight	195 kg	510 kg	440 kg			



STANDARD EQUIPMENT

ENGINE/POWER TRAIN:

- Engine, Komatsu SAA4D107E-1 diesel
- Engine shut-off system, electric
- Fuel pre-filter with water separator
- Service brakes, wet multiple-disc type
- Transmission (Hydrostatic with speed range select), automatic
- Wet disc parking brake

ELECTRICAL SYSTEM:

- Alternator, 60 A
- Back-up alarm
- Batteries, 2 x 12 V/88 Ah
- Lights
 - 4 front, 2 rear
 - Back up
 - Turn signal with hazard
- Starting motor, 24 V/4.5 kW

HYDRAULIC SYSTEM:

- 2-spool valve for boom and bucket controls
- Hydraulic driven fan with reverse rotation
- Hydraulic oil cooler
- Lift cylinders and bucket cylinder

CAB:

- Air conditioner
- Auto shift transmission with mode select system
- Cigarette lighter (24 V) and ashtray
- Floor mat
- Front & rear window washer and wiper
- Main monitor panel with Equipment Management Monitoring System
- PPC hydraulic control, mono lever
- Rear heated glass (Electric)

- Rear under view mirror
- Rear view mirror for cab
- ROPS/FOPS (ISO 3471/ISO 3449) cab
- Seat, rigid type with reclining
- Seat belt
- Steering wheel, tiltable
- Sun visor

WORK EQUIPMENT:

- Bucket positioner
- Counterweight
- Loader linkage with standard lift boom

OTHER EQUIPMENT:

- Radiator mask, lattice type
- Tires (17.5-25-12PR, L-3 tubeless)



OPTIONAL EQUIPMENT

ENGINE/POWER TRAIN:

- Engine pre-cleaner with extension
- Limited slip differential (Front & rear)
- Power train guard

ELECTRICAL SYSTEM:

- 12 V outlet
- Battery disconnect switch

HYDRAULIC SYSTEM:

- 3-spool valve
- Hydraulic driven fan with automatic reverse rotation
- Secondary steering (SAE)

CAB:

- AM/FM radio
- AM/FM stereo radio cassette
- Cool & heater box
- Deluxe suspension seat
- ROPS (ISO 3471) canopy

WORK EQUIPMENT:

- Additional counterweight
- Bolt on Cutting Edges (B.O.C.)
- Boom kick-out
- Bucket teeth (Bolt-on type)
- High lift boom

OTHER EQUIPMENT:

- Electronically Controlled Suspension System
- Fire extinguisher
- Front fenders
- Ordinary spare parts
- Rear full fenders
- Rear view monitoring system
- Tool kit
- Vandalism protection kit

KOMATSU TOTAL SUPPORT**Komatsu Total Support**

To keep your machine available and minimize operation cost when you need it, Komatsu Distributor is ready to provide a variety of supports before and after procuring the machine.

Fleet recommendation

Komatsu Distributor can study the customer's job site and provide the most optimum fleet recommendation with detailed information to meet all of your application needs when you are considering to buy new machines or replace the existing ones from Komatsu.

Product support

Komatsu Distributor gives the proactive support and secures the quality of the machinery that will be delivered.

Parts availability

Komatsu Distributor is available for emergency inquiry by the customers for genuine, quality guaranteed Komatsu parts.

Technical support

Komatsu product support service (Technical support) is designed to help customer. Komatsu Distributor offers a variety of effective services to show how much Komatsu is dedicated to the maintenance and support of Komatsu machine.

- Preventive Maintenance (PM) clinic
- Oil & Wear analysis program

Repair & maintenance service

Komatsu Distributor offers quality repair and maintenance service to the customer, utilizing and promoting Komatsu developed programs.

Komatsu Reman (Remanufactured) components

Komatsu Reman products are the result of the implementation of the Komatsu global policy which establishes and agrees to reduce the owning, operating and total Life Cycle Costs (LCC) to Komatsu's customer through high quality, prompt delivery and competitively priced in own remanufactured products (QDC).



