

KOMATSU®

D85EX-15R D85PX-15R

HORSEPOWER

Gross: 199 kW 266 HP @ 1900 rpm

Net: 197 kW 264 HP @ 1900 rpm

OPERATING WEIGHT

D85EX-15R: 28060 kg 61,862 lb

D85PX-15R: 27550 kg 60,740 lb

D
85

CRAWLER DOZER



Photo may include optional equipment.

WALK-AROUND

Komatsu-integrated design for the best value, reliability, and versatility. Hydraulics, power train, frame, and all other major components are engineered by Komatsu. You get a machine whose components are designed to work together for higher production, greater reliability, and more versatility.

SAA6D125E-5 turbocharged after-cooled diesel engine provides an output of **197 kW** 264 HP with excellent productivity. This engine is EPA Tier 2 and EU Stage 2 emissions equivalent. See page 6.

Hydraulic drive radiator cooling fan controlled automatically, reduces fuel consumption and operating noise levels. See page 6.

Preventative maintenance

- Centralized service station
- Enclosed hydraulic piping
- Modular power train design

See page 8.

Simple hull frame

and monocoque track frame with pivot shaft for greater reliability. See page 8.

Large blade capacities:

D85EX:

5.2 m³ 6.8 yd³ (Straight tilt dozer)

7.0 m³ 9.2 yd³ (Semi-U tilt dozer)

D85PX:

5.9 m³ 7.7 yd³ (Straight tilt dozer)

See page 6.

The track link life is greatly improved through increased bushing diameter and link height in addition to lubricated track. See page 8.

Low-drive, long-track, undercarriage ensures outstanding grading ability and stability. See page 6.



New hexagonal designed cab includes:

- Spacious interior
- Comfortable ride with new cab damper
- Excellent visibility
- High capacity air conditioning system (optional)
- Palm Command Control System (PCCS) lever
- Pressurized cab (optional)
- Adjustable armrests

Extra-low machine profile provides excellent machine balance and low center of gravity.

HORSEPOWER

Gross: 199 kW 266 HP @ 1900 rpm

Net: 197 kW 264 HP @ 1900 rpm

OPERATING WEIGHT

D85EX-15R 28060 kg 61,862 lb

D85PX-15R 27550 kg 60,740 lb

BLADE CAPACITY

Semi-U Tilt Dozer:

D85EX-15R: 7.0 m³ 9.2 yd³

Straight Tilt Dozer:

D85EX-15R: 5.2 m³ 6.8 yd³

D85PX-15R: 5.9 m³ 7.7 yd³

***Hydrostatic Steering System (HSS)***

provides smooth, quick and powerful control in various ground conditions.

See page 5.

Filtration

Further enhanced reliability of the machine against fuel contamination thanks to the improvement in fuel filtration.

See page 9.

Photo may include optional equipment.

PALM COMMAND CONTROL SYSTEM (PCCS)

Komatsu's new ergonomically designed control system "PCCS" creates an operating environment with *"complete operator control."*

Human-machine interface

Palm command electronic controlled travel control joystick

Palm command travel joystick provides the operator with a relaxed posture and superb fine control without operator fatigue. Transmission gear shifting is simplified with thumb push buttons.



Palm command PPC controlled blade control joystick

Blade control joystick uses the Proportional Pressure Control (PPC) valve and joystick is similar to the travel control joystick. PPC control combined with the highly reliable Komatsu hydraulic system enables superb fine control.

Blade and ripper control joystick



Full-adjustable suspension seat and travel control console

The travel control console has adjustment fore and aft, and height.

For improved rear visibility during reverse operations, the operator can adjust seat 15° to the right. (opt)

Fuel control dial

Engine revolution is controlled by electric signal, providing ease of operation, eliminating maintenance of linkage and joints.

Height adjustable armrest

Armrest is height adjustable without any tools, providing the operator with firm arm support in an ideal armrest.

Facing front



When turned 15° (opt)



Outline of electronic control system

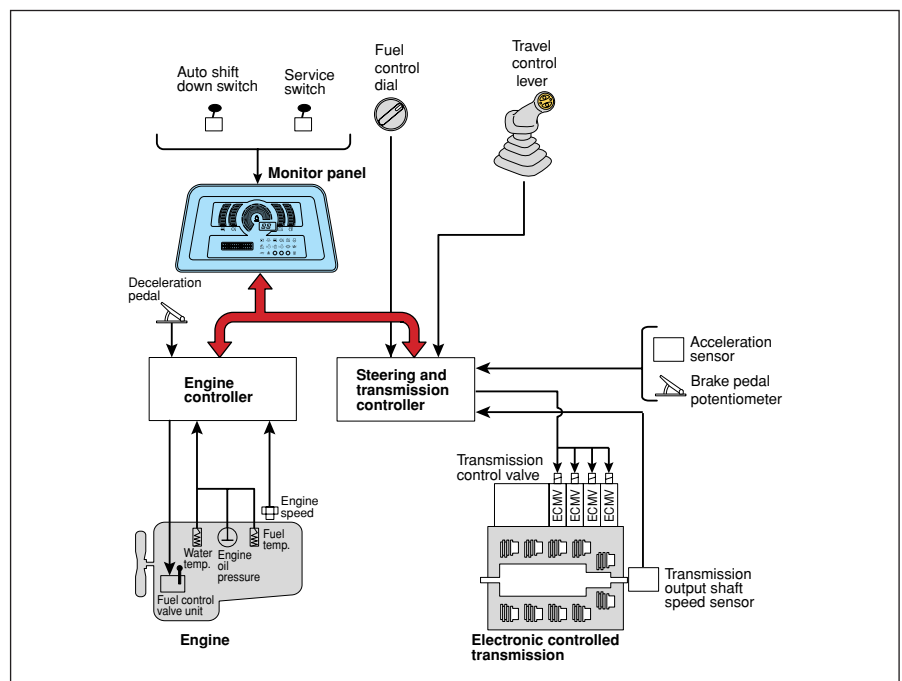

Power train electronic control system

Smooth and soft operation

D85EX/PX utilizes a newly designed power train electronic control system. The controller registers the amount of operator control (movements of lever and operation of switches) along with machine condition signals from each sensor, to calculate accurately the control of the transmission for optimal machine operation. The ease of operation and productivity of the new D85EX/PX is greatly improved through these new features.

Electronic Controlled Modulation Valve (ECMV) controlled transmission

Controller automatically adjusts each clutch engagement depending on travel conditions such as gear speed, revolution and shifting pattern. This provides smooth shockless clutch engagement, improved component reliability, improved component life and operator ride comfort.

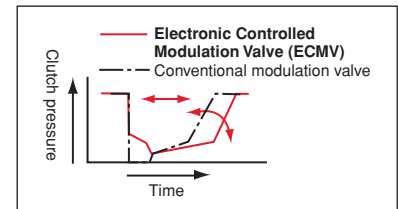

Hydrostatic Steering System—smooth, powerful turning

The Hydrostatic Steering System (HSS) is powered by an independent hydraulic pump with engine power transmitted to both tracks without power interruption on the inside track. When the machine turns, the outside track moves faster and the inside slower, for smooth, powerful turns. Counter-rotation is available for minimum turning radius providing excellent maneuverability. Shock-free steering reduces machine vibration and minimizes operator fatigue.

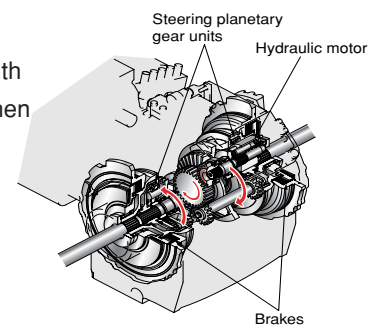

- Turning while dozing—the machine turns by driving the left and right tracks under power at different speeds allowing the machine to travel at the same speed as in straight dozing.
- Side cutting—when side-loading the blade, straight travel can be maintained utilizing HSS.
- On downhill slopes—the machine doesn't require counter-steering. The joystick provides the same steering response on downhill slopes as on flat ground.
- Grading—can be done efficiently without damaging the ground, because the inside track is not locked during turning.

Preset travel speed function

Preset travel speed selection function is provided as standard equipment. The preset switch enables the operator to select a combination of forward/reverse gear shifts, from 4 patterns; F1-R1, F1-R2, F2-R1 and F2-R2, by using UP/DOWN shift switch, and once the shift pattern is selected, operator can control the machine concentrating his attention on directional control only. Once F2-R2 pattern is selected, for example, 2nd gear is automatically selected when travel control joystick is moved into forward/reverse. This function reduces gear shifting frequency during machine operation and is especially helpful when used in combination with Auto-Downshift Function.

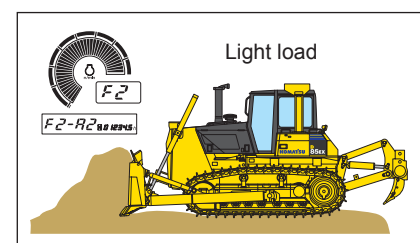
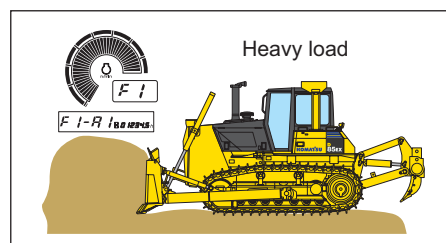
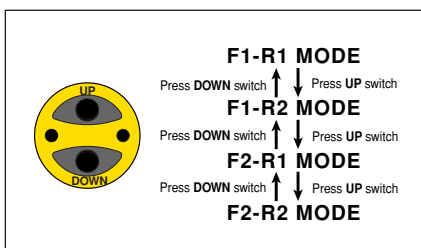

Auto downshift function

Controller monitors engine speed, travel gear and travel speed. When load is applied and machine travel speed is reduced, the controller automatically downshifts to optimize gear speed to provide high fuel efficiency. This function provides comfortable operation and high productivity without manual downshifting. (This function can be deactivated with cancel switch.)

Actuated on heavy load or steep slope

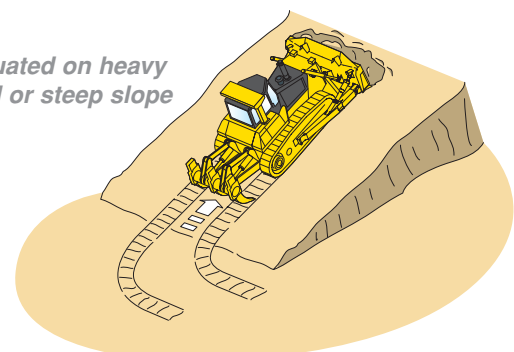

PRODUCTIVITY FEATURES

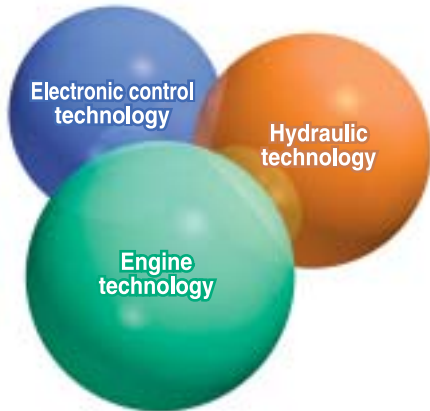

Engine

The Komatsu SAA6D125E-5 engine delivers **197 kW** 264 HP at 1900 rpm. The fuel-efficient Komatsu engine, together with the heavy machine weight, make the D85EX/PX superior crawler dozers in both ripping and dozing operations. This engine is EPA Tier 2 and EU Stage 2 emissions equivalent, and features direct fuel injection, turbocharger, and air-to-air aftercooler to maximize fuel efficiency. To minimize noise and vibration, the engine is mounted to the main frame with rubber cushions.

Hydraulic drive radiator cooling fan

Fan rotation is automatically controlled depending on coolant and hydraulic oil temperature, saving fuel consumption and providing great productivity with a quiet operating environment.

Undercarriage

Low drive and long track undercarriage

Komatsu's design is extraordinarily tough and offers excellent grading ability and stability. Large-diameter bushings, increased track link heights, and improved oil-seals help to increase undercarriage durability.

Improvements

Numerous improvements to increase undercarriage reliability and durability have been incorporated. Serviceability has also been improved with the addition of remote greasing of the equalizer bar center pin.



Work equipment

Large blade

Capacities of **5.2 m³** 6.8 yd³ (Straight tilt dozer for D85EX), **5.9 m³** 7.7 yd³ (D85PX), **7.0m³** 9.2 yd³ (Semi-U tilt dozer for D85EX) yield outstanding production. High-tensile-strength steel has been incorporated into the front and sides of the blade for increased durability.

Rippers (EX)

- The multi-shank ripper features a long sprocket center-to-ripper point distance, making ripping operation easy and effective while maintaining high penetration force.
- The multi-shank ripper is a parallelogram type ideal for ripping in tough material. The ripping depth is adjustable in two stages.



WORKING ENVIRONMENT

Operator comfort

Operator comfort is essential for productive work. The D85EX/PX provides a quiet, comfortable environment where the operator can concentrate on the work at hand.



Hexagonal pressurized cab

- The cab's new hexagonal design and large tinted glass windows provide excellent front, side and rear visibility.
- Air filters and a higher internal air pressure combine to prevent dust from entering the cab.



Photo may include optional equipment.

Comfortable ride with new cab damper mounting

D85EX/PX's cab mount uses a new cab damper which provides excellent shock and vibration absorption capacity with its long stroke. Cab damper mounts soften shocks and vibration while traveling over adverse conditions, which conventional mounting systems are unable to absorb. The cab damper spring isolates the cab from machine chassis, suppressing vibration and providing a quiet, comfortable operating environment.

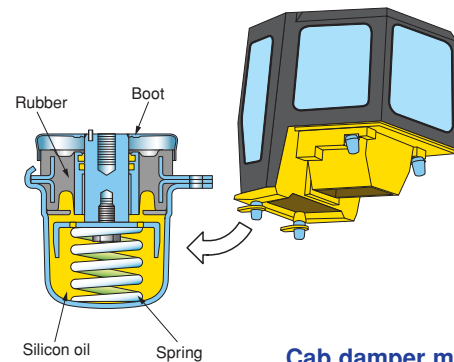

Cab damper mounting

New suspension seat

D85EX/PX uses a new suspension seat. Fore and aft sliding rails and suspension spring increase strength and rigidity. The new seat provides excellent support, improving riding comfort. Fore and aft seat travel can be adjusted to accommodate different operator sizes.



EASY MAINTENANCE

Preventative maintenance

Preventative maintenance is the only way to ensure long service life from your equipment. That's why Komatsu designed the D85EX/PX with conveniently located maintenance points to make necessary inspections and maintenance quick and easy.

Centralized service station

To assure convenient maintenance, the transmission and HSS oil filters, power train oil level gauges and hydraulic tank are arranged in the right side of the machine.



Monitor with self-diagnostic function

With the starting switch turned ON, the monitor displays check-before-starting and caution items appear on the lower right part of the panel. If the monitor finds abnormalities, corresponding warning lamp blinks and warning buzzer sounds. The monitor displays engine rpm and forward/reverse gear speed on the upper part of the monitor during operation. If abnormalities occur during operation, user code appears on display. When a critical user code is displayed, the caution lamp blinks and a warning buzzer sounds to prevent the development of serious problems.

Easy cleaning with hydraulic drive radiator fan

The radiator core and the core on the front side of the oil cooler can be easily cleaned by running the hydraulic engine fan in reverse. Accordingly, the cleaning intervals of those cores can be increased.

Enclosed hydraulic piping

Hydraulic piping for the blade tilt cylinder is completely housed in the push arm, ensuring damage protection from materials.

Modular power train design

Power train components are sealed in a modular design that allows the components to be dismantled and mounted without oil spillage.

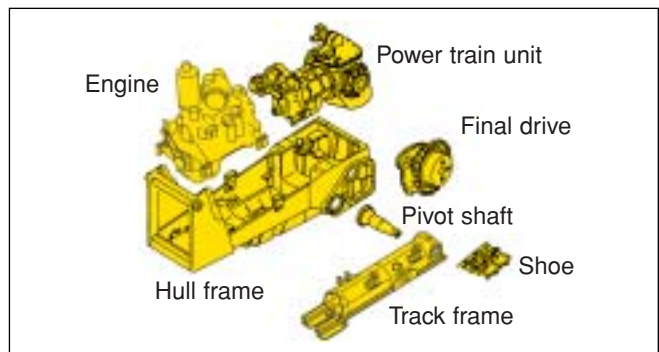

Reliable simple structure

Simple hull structure main frame design increases durability and reduces stress concentration at critical areas. The track frame has a large cross section and utilizes pivot shaft mounting for greater reliability.

Maintenance free disc brakes

Wet disc brakes require less maintenance.

Gull-wing engine side covers

The opening area is further enlarged when gull-wing engine side covers are opened, facilitating engine maintenance and filter replacement. Side covers have been changed to a thick one-piece structure with a bolt-on catch to improve durability.



Heavy-duty track link

The track link life is greatly improved through increased bushing diameter and link height in addition to lubricated track.

RELIABILITY FEATURES

Filtration

Engine

This machine is equipped a new high efficient main fuel filter of 2 μ m and water separator protect the engine against dirt and water in the fuel.



The fuel tank is equipped with a high-filtration breather with pressure valve to prevent dust from entering.



Hydraulic

The hydraulic tank is equipped with a high-filtration breather with pressure valve to help prevent dust from entering.





DIMENSIONS

	D85EX-15R		D85PX-15R	
A	2000 mm	6'7"	2250 mm	7'5"
B	3635 mm	11'11"	4365 mm	14'4"
C	3330 mm	10'11"	3330 mm	10'11"
D	3050 mm	10'	3480 mm	11'5"
E	5795 mm	19'	6065 mm	19'11"
F	1490 mm	4'11"	—	—
G	72 mm	2.8"	72 mm	2.8"
H	3324 mm	10'11"	3324 mm	10'11"

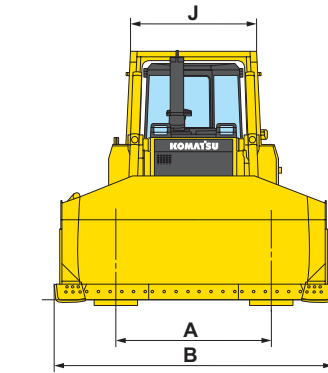

Ground clearance: 450 mm 1'6"

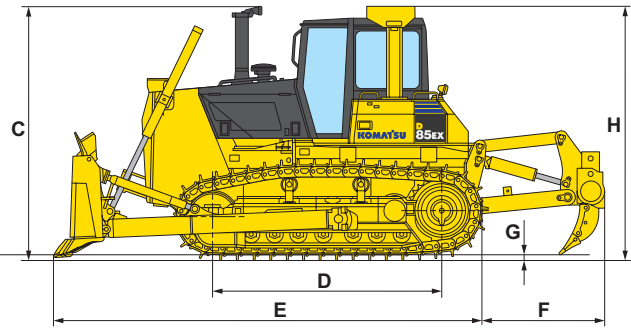

Dimensions with semi-U tilt dozer and multi-shank ripper (D85EX)



OPERATING WEIGHT

Tractor weight:

Including rated capacity of lubricant, coolant, full fuel tank, operator, and standard equipment.

D85EX-15R	21120 kg	46,560 lb
D85PX-15R	23400 kg	51,590 lb

Operating weight

Including Semi-U tilt dozer (EX) or straight tilt dozer (PX), multi-shank ripper (EX), steel cab, ROPS, operator, standard equipment, rated capacity of lubricant, coolant, and full fuel tank.

D85EX-15R	28060 kg	61,862 lb
D85PX-15R	27550 kg	60,740 lb



HYDRAULIC SYSTEM

Closed-center load sensing system (CLSS) designed for precise and responsive control, and for efficient simultaneous operation.

Hydraulic control units:

All spool valves externally mounted beside the hydraulic tank.
Plunger type hydraulic pump with capacity (discharge flow) of **195 ltr/min** 51.5 U.S. gal/min at rated engine rpm.

Relief valve setting **22.6 MPa** 230 kg/cm² 3,270 psi

Control valves:

Spool control valves for tilt dozer

- Positions: Blade lift Raise, hold, lower, and float
- Blade tilt. Right, hold, and left

Additional control valve required for multi-shank ripper (EX)

- Positions: Ripper lift Raise, hold, and lower

Hydraulic cylinders Double-acting, piston

	Number of cylinders	Bore
Blade lift	2	100 mm 3.9"
Blade tilt	1	150 mm 5.9"
Ripper lift	2	130 mm 5.1"

Hydraulic oil capacity (refill):

Straight tilt dozer	67 ltr	17.7 U.S. gal
Semi-U tilt dozer	67 ltr	17.7 U.S. gal
Ripper equipment (additional volume):		
Multi-shank ripper	11 ltr	2.9 U.S. gal



DOZER EQUIPMENT

Blade capacities are based on the SAE recommended practice J1265.

	Overall length with dozer	Blade capacity	Blade length x height	Maximum lift above ground	Maximum drop below ground	Maximum tilt adjustment	Weight		Ground pressure*
							Dozer equipment	Hydraulic oil	
D85EX-15R Straight tilt dozer	5640 mm 18'6"	5.2 m ³ 6.8 yd ³	3715 mm x 1436 mm 12'2" x 4'9"	1210 mm 4'	540 mm 1'9"	750 mm 2'6"	3305 kg 7,290 lb	24 kg 53 lb	72.6 kPa 0.74 kg/cm ² 10.5 psi
D85EX-15R Semi-U tilt dozer	5795 mm 19'	7.0 m ³ 9.2 yd ³	3635 mm x 1580 mm 11'11" x 5'2"	1210 mm 4'	540 mm 1'9"	735 mm 2'5"	3575 kg 7,890 lb	24 kg 53 lb	73.6 kPa 0.75 kg/cm ² 10.7 psi
D85PX-15R Straight tilt dozer	6065 mm 19'11"	5.9 m ³ 7.7 yd ³	4365 mm x 1370 mm 14'4" x 4'6"	1230 mm 4'	570 mm 1'10"	500 mm 1'8"	3343 kg 7,370 lb	23 kg 51 lb	43.1 kPa 0.44 kg/cm ² 6.3 psi
D85EX-15R Mechanical angle power tilt dozer	6035 mm 19'10"	4.0 m ³ 5.2 yd ³	4515 mm x 1130 mm 14'10" x 3'8"	1173 mm 3'10"	760 mm 2'6"	520 mm 1'8"	3730 kg 8,220 lb	24 kg 53 lb	73.6 kPa 0.75 kg/cm ² 10.7 psi

* Ground pressure shows tractor, cab, ROPS canopy operator, standard equipment and applicable blade.



STANDARD EQUIPMENT

- Alternator 50 ampere/24V
- Back up alarm
- Batteries 140 Ah/2 x 12V
- Decelerator pedal
- Dry-type air cleaner with dust evacuator and dust indicator
- Engine hood
- Final drive case wear guard
- Front pull hook
- Hinged front mask, perforated
- Hydraulic drive radiator cooling fan
- Hydraulic track adjusters
- Hydrostatic steering system (HSS)
- Lighting system (including two front and rear lights)
- Muffler with rain cap
- Palm lever steering control
- Perforated side covers
- Radiator reserve tank
- Rear cover
- Segmented sprockets
- Shoes:
 - 560 mm 22" single-grouser (EX)
 - 910mm 36" single-grouser (PX)
- Starting motor 7.5 kW/24 V
- Suspension seat and reclining
- TORQFLOW transmission
- Track frames
- Track roller guards, full length (EX), center and end section (PX)
- Warning horn
- Water separator

ROPS canopy (without cab):*

Weight. **437 kg** 970 lb

Roof dimensions

Length **1368 mm** 4'6"

Width **1850 mm** 6'1"

Height from

compartment floor. **1768 mm** 5'10"

*Meets ISO 3471 and SAE J/ISO 3471 ROPS standards, as well as ISO 3449 FOPS standard.



OPTIONAL EQUIPMENT

- Air conditioner
- Alternator 75 ampere/24 V
- AM-FM radio with cassette
- Batteries 200 Ah/2 x 12V
- Fire extinguisher
- First-aid kit
- Heater and defroster
- Light for ripper point
- Lunch box
- Mirror, rearview
- Panel cover
- Seat belt
- Shoes:
 - 610 mm 24" Single grouser shoe (EX)
 - 660 mm 26" Single grouser shoes (EX)
 - 910 mm 36" Swamp shoes (PX)
- Starting motor 11 kW/24V
- Sun visor
- Suspension seat, turn, fabric material
- Thermos
- Tool kit
- Vandalism protection kit

ROPS for cab:*

Weight. **371 kg** 820 lb

Roof dimensions

Length **650 mm** 2'2"

Width **1774 mm** 5'10"

Height from

compartment floor. **1754 mm** 5'9"

*Meets ISO 3471 and SAE J/ISO 3471 ROPS standards.

Steel cab:*

Weight. **410 kg** 910 lb

Dimensions:

Length **1758 mm** 5'9"

Width **1323 mm** 4'4"

Height from compartment

floor to ceiling **1592 mm** 5'3"

*Meets ISO 3449 FOPS standard.

Multi-shank ripper (EX):

Hydraulically controlled parallelogram ripper with three shanks.

Weight (including hydraulic control unit) **2560 kg** 5,644 lb

Beam length **2250 mm** 7'4"

Maximum lift above ground . . . **595 mm** 1'11"

Maximum digging depth **660 mm** 2'2"

