

KOMATSU®

HORSEPOWER

Gross: 155 kW 207 HP @ 1950 rpm

Net: 153 kW 205 HP @ 1950 rpm

OPERATING WEIGHT

D65EX-16 19540 kg 43,080 lb

D65PX-16 21020 kg 46,340 lb

D65WX-16 20400 kg 44,970 lb

D65EX-16 D65PX-16 D65WX-16

ecot3

D
65



Photo may include optional equipment.

CRAWLER DOZER

WALK-AROUND

OUTSTANDING PRODUCTIVITY & FUEL ECONOMY

Innovative SIGMADOZER reduces digging resistance and smoothly rolls material up for increased blade loads.

Blade capacity **5.6 m³** 7.3 yd³ (for EX)
5.9 m³ 7.7 yd³ (for WX) See page 4.

Automatic transmission with lockup torque converter improves fuel consumption. See page 5.

SAA6D114E turbocharged after-cooled diesel engine provides an output of **155 kW** 207 HP with excellent fuel economy. This engine is U.S. EPA Tier 3 and EU stage 3A emissions certified. See page 6.

Hydraulic drive radiator cooling fan controlled automatically, reduces fuel consumption and operating noise levels. See page 6.

Gull-wing engine side covers for easy and efficient engine servicing
See page 9.

Blade tilt lines completely protected

Parallel Link Undercarriage System (PLUS) provides longer wear life and lower repair & maintenance costs with new rotating bushings and other key enhancements. See page 9.

Power Angle Tilt (PAT) Dozer expands productivity in a variety of applications. The manually adjustable blade pitch further expands versatility and productivity. See page 8.

Complete operator control with Palm Command Control System (PCCS)

- Electronic controlled PCCS travel control
- Hydraulic controlled PCCS blade/ripper control
- Fuel control dial
- Automatic/manual gearshift selectable mode
- Gearshift pattern preset function
- ECMV controlled transmission

See page 7.

Increased-track length for EX/WX ensures outstanding grading ability and stability.

Extra-low machine profile provides excellent machine balance and low center of gravity.



HORSEPOWER

Gross: 155 kW 207 HP @ 1950 rpm
 Net: 153 kW 205 HP @ 1950 rpm

OPERATING WEIGHT

D65EX-16: 19540 kg 43,080 lb
 D65PX-16: 21020 kg 46,340 lb
 D65WX-16: 20400 kg 44,970 lb

BLADE CAPACITY

SIGMADOZER:

D65EX-16: 5.61 m³ 7.34 yd³
 D65WX-16: 5.90 m³ 7.72 yd³

Straight Tilt Dozer:

D65EX-16: 3.89 m³ 5.09 yd³
 D65PX-16: 3.69 m³ 4.83 yd³

Power Angle and Tilt Dozer:

D65EX-16: 4.25 m³ 5.56 yd³
 D65PX-16: 4.42 m³ 5.78 yd³
 D65 WX-16: 4.42 m³ 5.78 yd³

New integrated ROPS cab includes:

- Large quiet operator environment
- Comfortable ride with new cab damper
- Excellent visibility without ROPS post
- Automatic high capacity air conditioning
- Pressurized cab
- Adjustable armrest and suspension seat

See page 8.

Hydrostatic Steering System (HSS)

provides smooth, quick, and powerful control in various ground conditions.

See page 7.

**Large Liquid Crystal Display (LCD) monitor**

- Easy-to-read and use 7" large multi-color monitor
- Choice of 10 languages for global support

See page 8.

Automatic adjusted idler support

provides long life of wear plate without gap and vibration. See page 9.

High-rigidity, simple hull frame

and monocoque track frame with pivot shaft for greater reliability. See page 9.



Photos may include optional equipment.

Modular power train for increased serviceability and durability. Forward mounted pivot shafts isolate final drives from blade loads. See page 9.

Wet, multiple-disc brakes adjustment free for excellent service life. See page 9.

PRODUCTIVITY & FUEL ECONOMY FEATURES

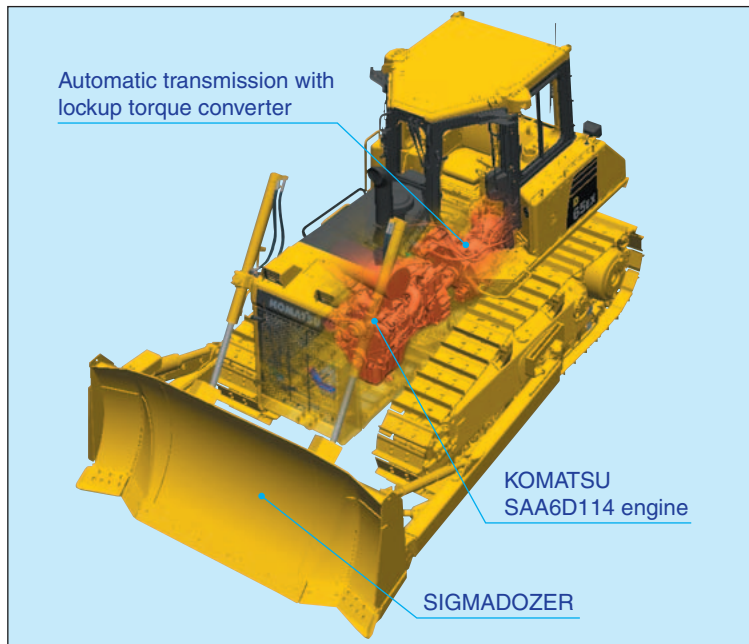

New fuel efficient bulldozer

The new D65 has achieved both high levels of productivity and fuel economy through the usage of SIGMADOZER and automatic transmission with lockup torque converter. SIGMADOZER developed based on completely new digging theory dramatically increases production. New transmission with high power transmission efficiency greatly reduces fuel consumption. This bulldozer significantly improves fuel efficiency compared with our conventional model.

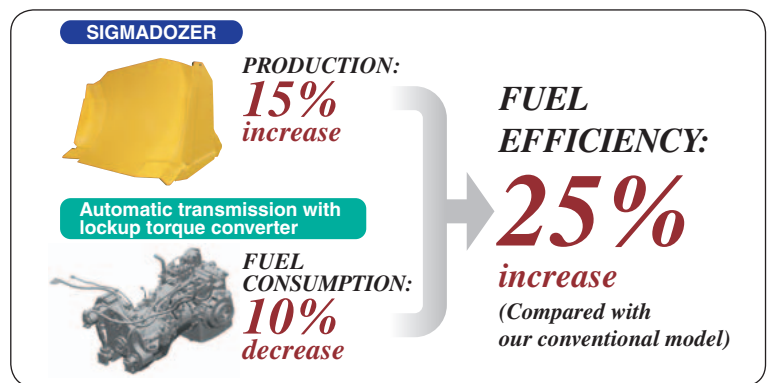

Outstanding productivity

SIGMADOZER – The next generation blade

Based on a completely new digging theory, SIGMADOZER dramatically improves dozing performance and increases productivity. A new frontal design concept adopted for digging and rolling up at the center of the blade increases soil holding capacity while simultaneously reducing sideways spillage. It also reduces digging resistance producing a

*Production increased by **15%***
(compared with our conventional model)

smoother flow of earth, enabling the dozing of larger quantities of soil with less power.



SIGMADOZER (D65-16)



Straight tilt blade (D65-15E0)

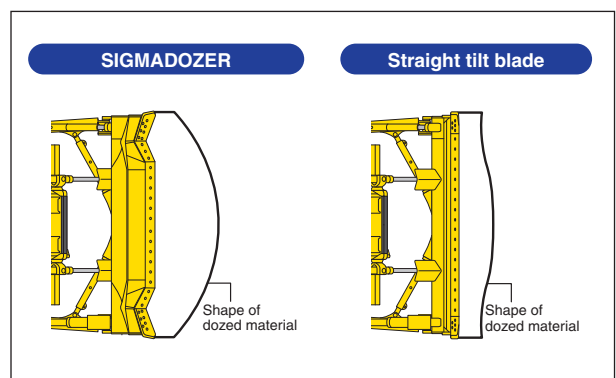

Outstanding fuel economy

Automatic transmission with lockup torque converter

A sharp reduction in fuel consumption and greater power train efficiency is achieved by the new automatic gearshift transmission and lockup torque converter. The automatic transmission selects the optimal gear range depending on the working conditions and load placed on the machine. This means the machine is always operating at maximum efficiency.

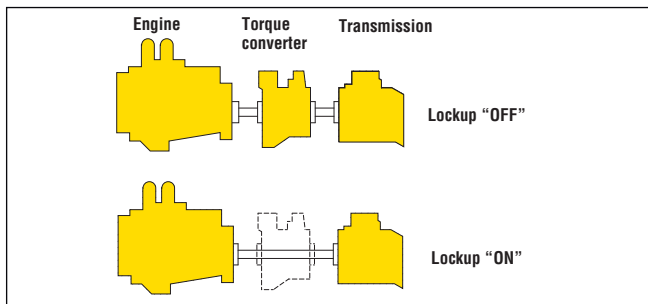

Fuel consumption decreased by 10%
(compared with our conventional model)

Lockup mechanism of the torque converter is automatically actuated to transfer engine power directly to the transmission in travelling and usual dozing speed ranges. Locking up the torque converter eliminates loss of power by 10%. Because the electronically controlled engine is extremely efficient, a decrease in fuel consumption is realized while also maintaining machine power.

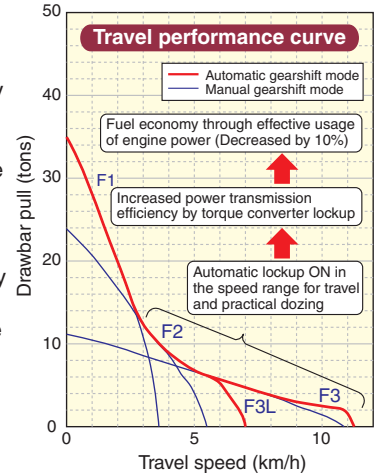

Automatic/manual gearshift selectable mode

Automatic or manual gearshift modes can be selected with ease to suit the work at hand by simply pressing the switch on the multi-monitor (selection at neutral).

- **Automatic gearshift mode**

Select for all general dozing. When a load is applied, the transmission automatically shifts down, and when the load is off, it automatically shifts up to a set maximum gear speed. This mode economizes both fuel and production further where the torque converter lockup mechanism is actuated according to load, providing a one to one drive.

- **Manual gearshift mode**

Select for dozing and ripping rough ground. When loaded, the transmission automatically shifts down, but does not shift up when the load is off.

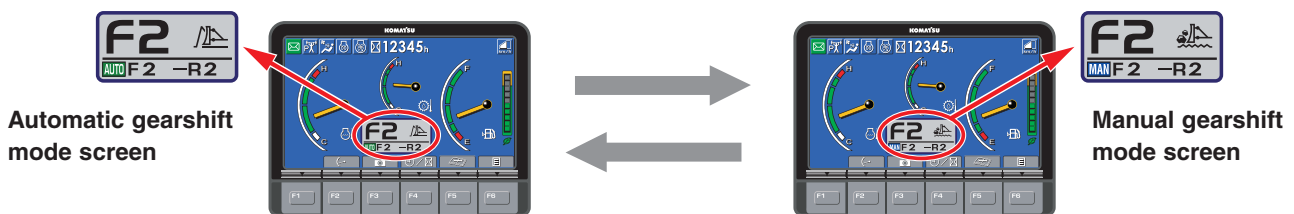

Selectable working mode

Working mode P is the mode aiming for powerful operation and maximum production and mode E for general dozing applications with adequate speed and power while saving energy. For CO₂ reduction and energy saving, the monitor panel allows for switching the working mode with ease, depending on the work at hand.

- **P mode (Power mode)**

With P mode, the engine outputs its full power, allowing the machine to perform the work requiring large production, heavy-load work, and uphill work.

- **E mode (Economy mode)**

With E mode, the engine outputs enough power for the work without delivering unnecessary power. This mode allows for energy saving operation and is suitable for the work on a ground where the machine may cause shoe slip and the work not requiring large power such as downhill dozing, leveling and light-load work.

ECOLOGY FEATURES



Komatsu develops and produces all major components, such as engines, electronics and hydraulic components in house.

Since all components can be matched, efficiencies are increased achieving high levels of productivity and ecology. With this "Komatsu Technology", and adding customer feedback, Komatsu is achieving great advancements in technology.

The result is a new generation of high performance and environment friendly machines.



Engine

Fuel efficient electronic controlled engine

The Komatsu SAA6D114E engine delivers **155 kW** 207 HP at 1950 rpm. The fuel-efficient, powerful Komatsu engine makes the D65 superior in both ripping and dozing operations. The engine is U.S. EPA Tier 3 and EU stage 3A emissions certified. The engine is turbocharged and features direct fuel injection and air-to-air aftercooling to maximize power, fuel efficiency and emission compliance. To minimize noise and vibration, the engine is mounted to the main frame with rubber cushions.

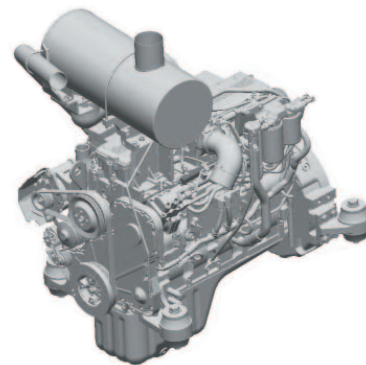

Hydraulic drive radiator cooling fan

The engine cooling fan rotation speed is electronically controlled. The fan rotation speed depends on engine coolant and hydraulic oil temperatures, the higher the temperature the higher the fan speed. This system increases fuel efficiency, reduces the operating noise levels and requires less horsepower than belt driven fan.

CONTROL FEATURES



Human-Machine Interface PCCS

Komatsu's ergonomically designed control system "PCCS" creates an operating environment with "complete operator control."

Palm command electronic controlled travel joystick

Palm command travel joystick provides the operator with a relaxed posture and superb fine control without operator fatigue. Transmission gear shifting is simplified with thumb push buttons.

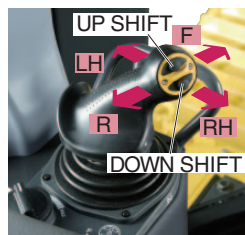

Palm command hydraulic controlled blade/ripper joystick

Hydraulically-controlled palm command joystick is equipped for blade/ripper control. Combined with the highly reliable Komatsu hydraulic system, superb control is the result.

Electronic Controlled Modulation Valve controlled transmission

A controller automatically adjusts each clutch engagement depending on travel conditions, providing smooth shockless clutch engagement, improved component life and operator ride comfort.

Gearshift pattern preset function

When the gearshift pattern is set to either <F1-R2>, <F2-R1>, <F2-R2>, <F2-R3L> or <F3L-R3L> in the automatic gearshift mode, the gear automatically shifts to the preset gear when the travel control joystick is set to Forward or Reverse position, reducing round trip repetition work time and operator's efforts. Gearshift pattern <F2-R3L> and <F3L-R3L> are newly added for high speed leveling operation.

Hydrostatic Steering System—smooth, powerful turning

The engine power is transmitted to both tracks without power interruption on the inside track for smooth, powerful turns. Counter-rotation is available for minimum turning radius enhancing maneuverability.

Automatic gearshift mode	Manual gearshift mode
 <p>F1-R1 MODE Press DOWN switch ↑ ↓ Press UP switch</p> <p>F1-R2 MODE Press DOWN switch ↑ ↓ Press UP switch</p> <p>F2-R1 MODE Press DOWN switch ↑ ↓ Press UP switch</p> <p>F2-R2 MODE Press DOWN switch ↑ ↓ Press UP switch</p> <p>F2-R3L MODE Press DOWN switch ↑ ↓ Press UP switch</p> <p>F3L-R3L MODE</p>	<p>F1-R1 MODE Press DOWN switch ↑ ↓ Press UP switch</p> <p>F1-R2 MODE Press DOWN switch ↑ ↓ Press UP switch</p> <p>F2-R1 MODE Press DOWN switch ↑ ↓ Press UP switch</p> <p>F2-R2 MODE Press DOWN switch ↑ ↓ Press UP switch</p> <p>F2-R3 MODE</p>



WORKING ENVIRONMENT



New integrated ROPS cab

A newly designed cab is integrated with ROPS according to the latest computer analysis. High rigidity and superb sealing performance sharply reduce noise and vibration for the operator and prevent dust from entering the cab. Relaxed operation in comfortable environment. In addition, side visibility is increased because external ROPS structure and posts are not required. Outstanding visibility has been achieved.

Large multi-lingual LCD color monitor

A large user-friendly color monitor enables safe, accurate and smooth work. Excellent screen visibility is achieved by use of LCD that can easily be read at various angles and lighting conditions. Simple and easy to operate switches. Plus function keys facilitate multi-function operations.

Display data in 10 languages to globally support operators around the world.

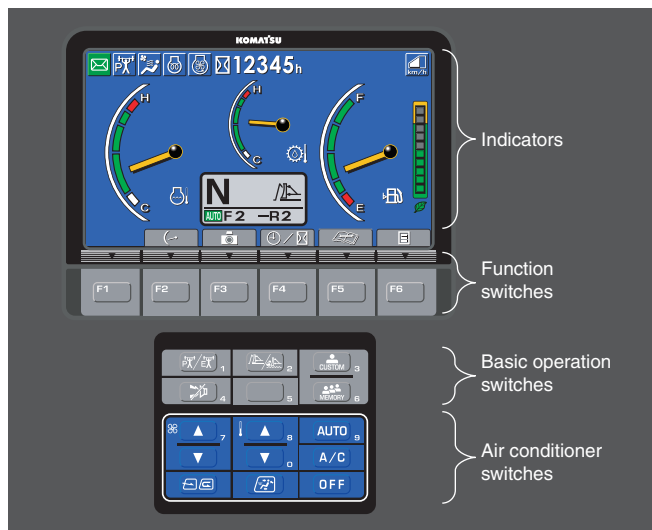

Comfortable ride with cab damper mounting

The D65's cab mount uses a cab damper which provides excellent shock and vibration absorption capacity. The long stroke cab damper mounts soften shocks and vibration while traveling over adverse conditions, which conventional rubber mounting systems are unable to absorb. The cab damper spring isolates the cab from the machine body, suppressing vibration and providing a quiet, comfortable operating environment.

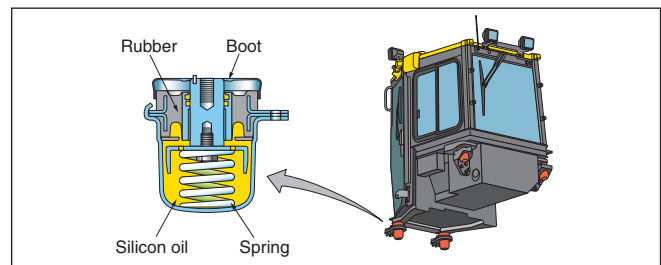

Power angle power tilt dozer (Optional)

A power angle and power tilt dozer blade with highly durable box-structure frame is optionally available. This dozer is available for the EX, WX and PX machines. The hydraulic blade tilt and angling function expands versatility and productivity in a variety of applications. The manually adjustable blade pitch further expands the versatility and productivity.

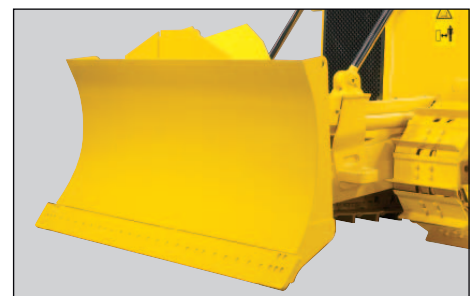

MAINTENANCE FEATURES

Preventative maintenance

Preventative maintenance is the only way to ensure long service life from your equipment. That's why Komatsu designed the D65 with conveniently located maintenance points to make necessary inspections and maintenance quick and easy.

Multi-monitor with troubleshooting function to prevent critical machine troubles

Various meters, gauges and warning functions are centrally arranged on the multi-monitor. The monitor simplifies start-up inspection and promptly warns the operator with a lamp and buzzer if any abnormalities should occur. In addition, countermeasures are indicated in 4 levels to ensure safety and prevent the machine from major problems. Replacement times for oil and filters are also indicated.



Easy radiator cleaning with hydraulic drive fan

The radiator can be cleaned by utilization of the reversible, hydraulically driven cooling fan. The fan can be reversed from inside the cab by simply activating a switch.

Oil pressure check ports

Pressure check ports for power train components are centralized to promote quick and simple diagnosis.

Gull-wing engine side covers

The engine side covers are gull-wing type with a gas spring, and the opening angle of the cover is further increased to facilitate engine maintenance and filter replacement.



Low maintenance costs

Parallel Link Undercarriage System (PLUS) (Optional)

Komatsu's innovative PLUS features a rotary bushing that demonstrates high durability in any working conditions. Allowing the bushing to rotate virtually eliminates bushing wear, resulting in doubled service life of the undercarriage when compared with the conventional undercarriage. In addition, wear limits of the link and carrier roller are increased to balance with the extended service life of the bushing.

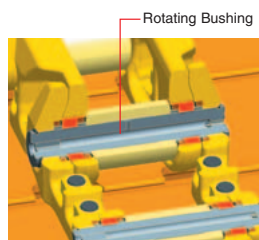

Self-adjusting idler support

Self-adjusting idler support applies a constant spring force to the wear plate of the idler guide to eliminate the play of the idler. This results in reduced noise and vibration as well as extends the service life of the wear plate.

Reliable simple hull frame

Simple hull structure main frame design increases durability and reduces stress concentration at critical areas. The track frame has a large cross section and utilizes pivot shaft mounting for greater reliability.

Sealed connectors

Main harnesses and controller connectors are equipped with sealed connectors providing high reliability, as well as water and dust resistance.

Flat face O-ring seals

Flat face O-ring seals are used to securely seal all hydraulic hose connections preventing leakage.

Enclosed hydraulic piping

Hydraulic piping for the blade tilt cylinder is completely housed in the push arm, protecting it from damage.

Modular power train design

Power train components are sealed in a modular design that allows the components to be removed and installed without oil spillage, making servicing work clean, smooth and easy.

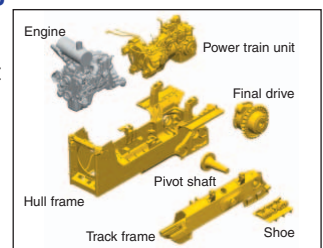

Adjustment-free disc brakes

Wet disc brakes are adjustment-free and provide excellent service life.

SPECIFICATIONS



ENGINE

Model Komatsu SAA6D114E-3
 Type 4-cycle, water-cooled, direct injection
 Aspiration Turbocharged, air-to-air aftercooled
 Number of cylinders 6
 Bore x stroke 114 mm x 135 mm 4.49" x 5.31"
 Piston displacement 8.27 ltr 505 in³
 Governor All-speed and mid-range, electronic
 Horsepower
 SAE J1995 Gross 155 kW 207 HP
 (ISO 14396 Maximum Gross 163.7 kW 219 HP)
 ISO 9249 / SAE J1349* Net 153 kW 205 HP
 Rated rpm 1950 rpm
 Fan drive type Hydraulic
 Lubrication system
 Method Gear pump, force lubrication
 Filter Full-flow
 *Net horsepower at the maximum speed of
 radiator cooling fan 139 kW 186 HP
 U.S. EPA Tier 3 and EU Stage 3A emissions certified.



TORQFLOW TRANSMISSION

Komatsu TORQFLOW transmission consists of a water-cooled, 3-element, 1-stage, 2-phase, torque converter with lockup clutch, and a planetary gear, multiple-disc clutch transmission which is hydraulically actuated and force-lubricated for optimum heat dissipation. Gearshift lock lever and neutral safety switch prevent machine from accidental starts.

Travel speed	Forward	Reverse
1st	3.6 km/h 2.2 mph	4.4 km/h 2.7 mph
2nd	5.5 km/h 3.4 mph	6.6 km/h 4.1 mph
3rdL	7.2 km/h 4.5 mph	8.6 km/h 5.3 mph
3rd	11.2 km/h 7.0 mph	13.4 km/h 8.3 mph

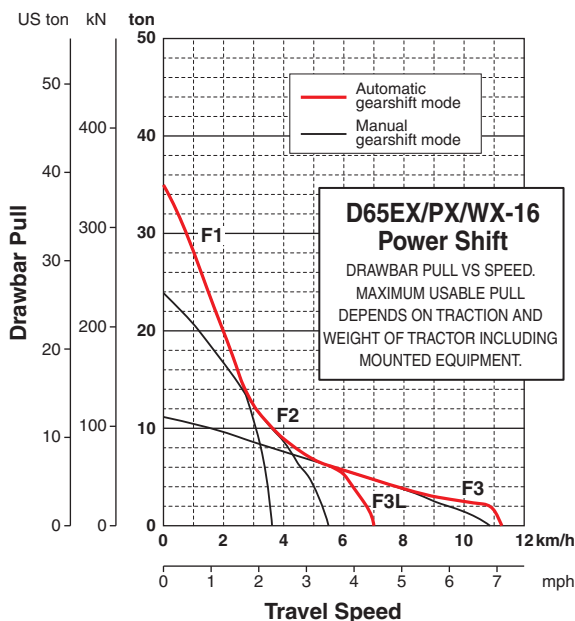

STEERING SYSTEM

PCCS lever controls for all directional movements. Pushing the PCCS lever forward results in forward machine travel, while pulling it rearward reverses the machine. Simply tilt the PCCS lever to left to make a left turn. Tilt it to the right for a right turn.

HSS is powered by steering planetary units and a hydraulic pump and motor. Counter-rotation turns are also available. Wet, multiple-disc, pedal-controlled service brakes are spring-actuated and hydraulically released. Gear shift lock lever also applies parking brake.

Minimum turning radius	D65EX-16.....	1.9 m 6'3"
	D65EX-16 with PAT.....	2.0 m 6'7"
	D65PX-16.....	2.2 m 7'3"
	D65WX-16.....	2.1 m 6'11"



UNDERCARRIAGE

Suspension Oscillating equalizer bar and pivot shaft
 Track roller frame Monocoque, large section, durable construction

Rollers and idlers Lubricated track rollers

Track shoes

Lubricated tracks. Unique seals prevent entry of foreign abrasive material into pin to bushing clearances to provide extended service life. Track tension is easily adjusted with grease gun.

	D65EX-16	D65PX-16	D65WX-16
Type of dozer	SIGMADOZER	Straight Tilt Dozer	SIGMADOZER
Number of track rollers (each side)	7	8	7
Type of shoes (standard)	Single grouser	Single grouser	Single grouser
Number of shoes (each side)	42	45	42
Grouser height	mm in 65 2.6"	65 2.6"	65 2.6"
Shoe width (standard)	mm in 510 20"	915 36"	760 30"
Ground contact area	cm ² in ² 30395 (30295) 4,711 (4,696)	60115 (59935) 9,318 (9,290)	45295 (45145) 7,021 (6,997)
Ground pressure (tractor)	kPa kgf/cm ² psi 55.3 (56.5) 0.56 (0.58) 8.02 (8.19)	30.8 (31.5) 0.31 (0.32) 4.47 (4.57)	38.7 (39.6) 0.40 (0.40) 5.61 (5.74)
Track gauge	mm ft.in 1880 6'2"	2050 6'9"	2050 6'9"
Length of track on ground	mm ft.in 2980 (2970) 9'9" (9'9")	3285 (3275) 10'9" (10'9")	2980 (2970) 9'9" (9'9")

for PAT Dozer

	D65EX-16	D65PX-16	D65WX-16
Type of dozer	Power Angle Power Tilt Dozer	Power Angle Power Tilt Dozer	Power Angle Power Tilt Dozer
Number of track rollers (each side)	7	8	7
Type of shoes (standard)	Single grouser	Single grouser	Single grouser
Number of shoes (each side)	42	45	42
Grouser height	mm in 65 2.6"	65 2.6"	65 2.6"
Shoe width (standard)	mm in 560 22"	760 30"	760 30"
Ground contact area	cm ² in ² 33375 (33265) 5,173 (5,156)	49930 (49780) 7,739 (7,716)	45295 (45145) 7,021 (6,997)
Ground pressure (tractor)	kPa kgf/cm ² psi 52.9 (54.0) 0.54 (0.55) 7.68 (7.84)	37.0 (37.8) 0.38 (0.39) 5.38 (5.49)	40.9 (41.7) 0.42 (0.43) 5.94 (6.05)
Track gauge	mm ft.in 2050 6'9"	2230 7'4"	2230 7'4"
Length of track on ground	mm ft.in 2980 (2970) 9'9" (9'9")	3285 (3275) 10'9" (10'9")	2980 (2970) 9'9" (9'9")

() ... PLUS spec.



FINAL DRIVES

Double-reduction final drive of spur and planetary gear sets to increase tractive effort and reduce gear tooth stresses for long final drive life. Segmented sprocket teeth are bolt-on for easy replacement.



COOLANT AND LUBRICANT CAPACITY (REFILL)

Fuel tank	415 ltr	109.6 U.S. gal
Coolant	36 ltr	9.5 U.S. gal
Engine	28 ltr	7.4 U.S. gal
Torque converter, transmission, bevel gear, and steering system	48 ltr	12.7 U.S. gal
Final drive (each side)		
D65EX-16	24 ltr	6.3 U.S. gal
D65EX-16 with PAT	27 ltr	7.1 U.S. gal
D65PX-16	27 ltr	7.1 U.S. gal
D65WX-16	27 ltr	7.1 U.S. gal



HYDRAULIC SYSTEM

Closed-center load sensing system (CLSS) designed for precise and responsive control, and for efficient simultaneous operation.

Hydraulic control units:

All spool valves externally mounted beside the hydraulic tank.
Plunger type hydraulic pump with capacity (discharge flow) of **248 ltr/min** 65.5 U.S. gal/min at rated engine rpm.

Relief valve setting **27.9 MPa** 285 kgf/cm² 4,050 psi

Control valves:

Spool control valves for SIGMADOZER or straight tilt dozer
Positions: Blade lift Raise, hold, lower, and float
Blade tilt Right, hold, and left

Spool control valves for power angle power tilt dozer
Positions: Blade lift Raise, hold, lower, and float
Blade tilt Right, hold, and left
Blade angle Right, hold, and left

Additional control valve required for multi-shank ripper (EX, WX)
Positions: Ripper lift Raise, hold, and lower

Hydraulic cylinders Double-acting, piston

	Number of cylinders	Bore	
		SIGMADOZER Straight Tilt Dozer	Power Angle Power Tilt Dozer
Blade lift	2	90 mm 3.5"	90 mm 3.5"
Blade tilt	1	125 mm 4.9"	130 mm 5.1"
Blade angle	2	—	110 mm 4.3"
Ripper lift	1	125 mm 4.9"	125 mm 4.9"

Hydraulic oil capacity (refill): **55 ltr** 14.5 U.S. gal

Ripper equipment (additional volume):

Multi-shank ripper **7 ltr** 1.8 U.S. gal



DOZER EQUIPMENT

Blade capacities are based on the ISO recommended practice 9246.

Use of high tensile strength steel in moldboard for strengthened blade construction.

	Overall Length With Dozer mm ft.in	Blade Capacity m ³ yd ³	Blade Width x Height mm ft.in	Max. Lift Above Ground mm ft.in	Max. Drop Below Ground mm ft.in	Max. Tilt Adjustment mm ft.in	Weight		Ground Pressure* kPa kgf/cm ² psi
							Dozer equipment kg lb		
D65EX-16 SIGMADOZER	5490 18'0"	5.61 7.34	3410 x 1425 11'2" x 4'8"	1130 (1135) 3'8" (3'9")	630 (625) 2'1" (2'1")	870 2'10"	2390 5,270		62.9/0.64/9.13 (64.1/0.65/9.31)
D65EX-16 semi-U Tilt Dozer	5510 18'1"	5.61 7.34	3460 x 1425 11'4" x 4'8"	1110 (1115) 3'8" (3'8")	560 (555) 1'10" (1'10")	855 2'10"	2320 5,115		62.9/0.64/9.13 (64.1/0.65/9.31)
D65EX-16 Straight Tilt Dozer	5330 17'6"	3.89 5.09	3415 x 1225 11'2" x 4'0"	1100 (1105) 3'7" (3'8")	555 (550) 1'10" (1'10")	870 2'10"	2060 4,540		61.8/0.63/8.98 (63.0/0.64/9.15)
D65EX-16 Power Angle Power Tilt Dozer	5790 19'0"	4.25 5.56	3870 x 1235 12'8" x 4'1"	1165 (1170) 3'10" (3'10")	700 (695) 2'4" (2'3")	500 1'8"	2960 6,530		61.6/0.63/8.95 (62.8/0.64/9.11)
D65EX-16 Angle Dozer	5540 18'2"	3.55 4.64	3970 x 1100 13'0" x 3'7"	1175 (1180) 3'10" (3'10")	570 (565) 1'10" (1'10")	400 1'4"	2200 4,850		62.3/0.64/9.04 (63.5/0.65/9.22)
D65PX-16 Straight Tilt Dozer	5680 18'8"	3.69 4.83	3970 x 1100 13'0" x 3'7"	1125 (1130) 3'8" (3'8")	580 (575) 1'11" (1'11")	890 2'11"	2100 4,630		34.2/0.35/4.97 (34.8/0.36/5.06)
D65PX-16 Power Angle Power Tilt Dozer	5790 19'0"	4.42 5.78	4010 x 1235 13'2" x 4'1"	1165 (1170) 3'10" (3'10")	700 (695) 2'4" (2'3")	520 1'8"	2990 6,590		42.9/0.44/6.23 (43.7/0.45/6.34)
D65WX-16 SIGMADOZER	5500 18'1"	5.90 7.72	3580 x 1425 11'9" x 4'8"	1130 (1135) 3'8" (3'9")	630 (625) 2'1" (2'1")	770 2'6"	2500 5,510		44.1/0.45/6.39 (44.9/0.46/6.51)
D65WX-16 Power Angle Power Tilt Dozer	5790 19'0"	4.42 5.78	4010 x 1235 13'2" x 4'1"	1165 (1170) 3'10" (3'10")	700 (695) 2'4" (2'3")	520 1'8"	2990 6,590		47.4/0.48/6.87 (48.2/0.49/7.00)

*Ground pressure shows tractor, ROPS cab, operator, standard equipment and applicable blade.

() ... PLUS spec.

D65EX/PX/WX-16 CRAWLER DOZER



DIMENSIONS

	D65EX-16 SIGMADOZER	D65PX-16 Straight Tilt Dozer	D65WX-16 SIGMADOZER
A	5490 mm 18'0"	5680 mm 18'8"	5500 mm 18'1"
B	1880 mm 6'2"	2050 mm 6'9"	2050 mm 6'9"
C	3155 mm 10'4" (3160 mm 10'4")	3155 mm 10'4" (3160 mm 10'4")	3155 mm 10'4" (3160 mm 10'4")
D	3080 mm 10'1" (3085 mm 10'1")	3080 mm 10'1" (3085 mm 10'1")	3080 mm 10'1" (3085 mm 10'1")
E	2980 mm 9'9" (2970 mm 9'9")	3285 mm 10'9" (3275 mm 10'9")	2980 mm 9'9" (2970 mm 9'9")
F	510 mm 20"	915 mm 36"	760 mm 30"
G	65 mm 2.6"	65 mm 2.6"	65 mm 2.6"

Ground clearance 410 mm 1'4" (415 mm 1'4")

() ... PLUS spec.

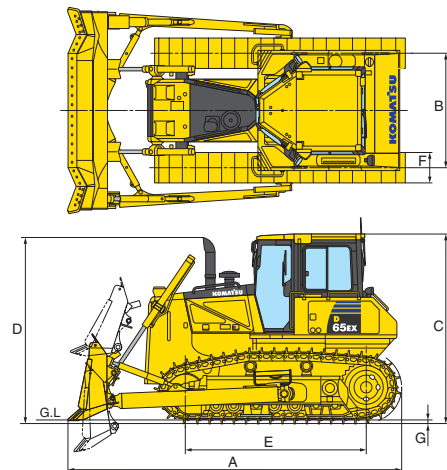
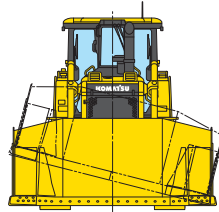

Dimension with SIGMADOZER (D65EX-16) single grouser shoe.

for PAT Dozer

	D65EX-16 PAT Dozer	D65PX-16 PAT Dozer	D65WX-16 PAT Dozer
A	5790 mm 19'0"	5790 mm 19'0"	5790 mm 19'0"
B	2050 mm 6'9"	2230 mm 7'4"	2230 mm 7'4"
C	3155 mm 10'4" (3160 mm 10'4")	3155 mm 10'4" (3160 mm 10'4")	3155 mm 10'4" (3160 mm 10'4")
D	3080 mm 10'1" (3085 mm 10'1")	3080 mm 10'1" (3085 mm 10'1")	3080 mm 10'1" (3085 mm 10'1")
E	2980 mm 9'9" (2970 mm 9'9")	3285 mm 10'9" (3275 mm 10'9")	2980 mm 9'9" (2970 mm 9'9")
F	560 mm 22"	760 mm 30"	760 mm 30"
G	65 mm 2.6"	65 mm 2.6"	65 mm 2.6"
H	3545 mm 11'8"	3670 mm 12'0"	3670 mm 12'0"

Ground clearance 410 mm 1'4" (415 mm 1'4")

() ... PLUS spec.

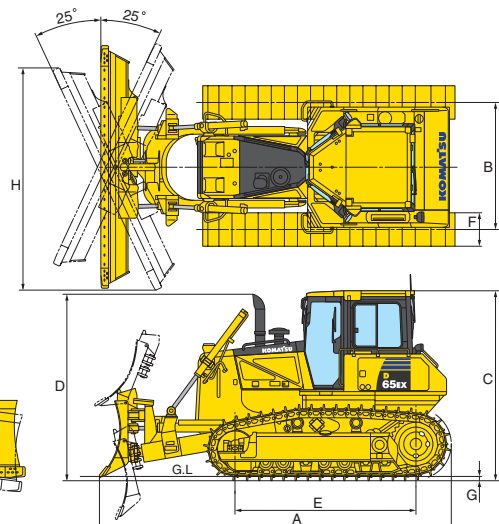
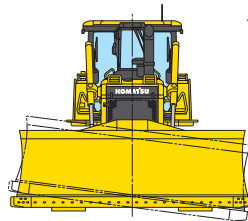

Dimension with Power angle power tilt dozer (D65EX-16) single grouser shoe.



OPERATING WEIGHT

Tractor weight:

Including ROPS cab, rated capacity of lubricant, hydraulic control unit, coolant, full fuel tank, operator, and standard equipment.

D65EX-16 **17150 kg** 37,810 lb (**17470 kg** 38,510 lb)
 D65PX-16 **18920 kg** 41,710 lb (**19240 kg** 42,420 lb)
 D65WX-16 **17900 kg** 39,460 lb (**18220 kg** 40,170 lb)

for PAT dozer

D65EX-16 **18030 kg** 39,750 lb (**18340 kg** 40,430 lb)
 D65PX-16 **18870 kg** 41,600 lb (**19210 kg** 42,350 lb)
 D65WX-16 **18900 kg** 41,670 lb (**19210 kg** 42,350 lb)

() ... PLUS spec.

Operating weight

Including SIGMADOZER (EX/WX) or straight tilt dozer (PX) or power angle power tilt dozer, ROPS cab, operator, standard equipment, rated capacity of lubricant, hydraulic control unit, coolant, and full fuel tank.

D65EX-16 **19540 kg** 43,080 lb (**19860 kg** 43,780 lb)
 D65PX-16 **21020 kg** 46,340 lb (**21340 kg** 47,050 lb)
 D65WX-16 **20400 kg** 44,970 lb (**20720 kg** 45,680 lb)

for PAT dozer

D65EX-16 **20990 kg** 46,270 lb (**21300 kg** 46,960 lb)
 D65PX-16 **21860 kg** 48,190 lb (**22200 kg** 48,940 lb)
 D65WX-16 **21890 kg** 48,260 lb (**22200 kg** 48,940 lb)

() ... PLUS spec.



STANDARD EQUIPMENT FOR BASE MACHINE

- Air cleaner, double element with dust indicator
 - Alternator, 60 ampere/24V
 - Backup alarm
 - Batteries, 140 Ah/2 x 12V
 - Color monitor
 - Decelerator pedal
 - Engine hood
 - Engine side covers, gull-wing
 - Fenders
 - High mount foot rests
 - Hydraulic drive radiator cooling fan with clean mode
 - Locks, filler caps and covers
 - Muffler with curved exhaust pipe
 - Oil pressure check ports for power train
 - Radiator mask, heavy-duty, hinged
 - Radiator reserve tank
 - Rear counterweight (EX, WX with PAT)
 - Rear cover
 - Seat, adjustable
 - Starting motor, 7.5 kW/24V
 - Steering system: HSS
 - Track roller guard, center and end section (PX)
 - Track roller guard, end sections (EX, WX)
 - Track shoe assembly
 - Heavy-Duty sealed and lubricated track
 - **510 mm 20"** single grouser shoe (EX)
 - **560 mm 22"** single grouser shoe (EX with PAT)
 - **760 mm 30"** single grouser shoe (WX)
 - **760 mm 30"** single grouser shoe (PX, WX with PAT)
 - **915 mm 36"** single grouser shoe (PX)
 - Underguards: oil pan and transmission heavy-duty
 - Water separator
 - ROPS cab*
 - Air conditioner
 - Air-conditioner intake precleaner
 - Cab accessories
 - 12V power supply
 - Cup holder
 - Rear view mirror
 - Sun visor
- * Meets ISO 3471, SAE J1040 APR88 ROPS standards, and ISO 3449 FOPS standard.



OPTIONAL EQUIPMENT

- Air suspension seat with turn, high-back
 - Alternator, 90 ampere/24V
 - AM-FM radio
 - Batteries 200 Ah/2 x 12 V
 - Engine intake precleaner
 - Front pull hook
 - Hinged underguards
 - Hitch type drawbar
 - Hydraulics for ripper (EX, WX)
 - Light working, cab additional
 - Rear view monitoring system
 - ROPS canopy
 - Rotary bushing link track (PLUS)
 - Starting motor 11.0 kW/24 V
 - Suspension seat with high-back
 - Tool kit
 - Track roller guard, full length
- Multi-shank ripper (for D65EX/WX):**
 Weight (including hydraulic control unit) **1770 kg** 3,900 lb
 Beam length **2170 mm** 7'1"
 Maximum lift above ground . . . **640 mm** 2'1"
 Maximum digging depth **590 mm** 1'11"

SHOES

Models	Shoe	Additional weight	Ground contact area	Additional ground pressure to tractor
D65EX	560 mm 22" single-grouser shoe	+130 kg (+130 kg) +290 lb (+290 lb)	33375 cm² (33265 cm²) 5,173 in ² (5,156 in ²)	-4.5 kPa (-4.7 kPa) -0.05 kgf/cm ² (-0.05 kgf/cm ²) -0.66 psi (-0.68 psi)
	610 mm 24" single-grouser shoe	+250 kg (+260 kg) +550 lb (+570 lb)	36355 cm² (36235 cm²) 5,635 in ² (5,616 in ²)	-8.4 kPa (-8.5 kPa) -0.09 kgf/cm ² (-0.09 kgf/cm ²) -1.22 psi (-1.24 psi)
	660 mm 26" single-grouser shoe	+380 kg (+390 kg) +840 lb (+860 lb)	39335 cm² (39205 cm²) 6,097 in ² (6,077 in ²)	-11.6 kPa (-11.8 kPa) -0.12 kgf/cm ² (-0.12 kgf/cm ²) -1.68 psi (-1.72 psi)
D65PX	940 mm 37" circular-arc shoe	+30 kg +70 lb	61760 cm² 9,573 in ²	-0.8 kPa -0.01 kgf/cm ² -0.11 psi

() ... PLUS spec.

MEMO

A series of horizontal dotted lines for writing, spanning the width of the page.

MEMO

A series of horizontal dotted lines for writing, spanning the width of the page.

Up to 20% blended paraffine fuel can be used. Please consult your Komatsu distributor for detail.

<https://home.komatsu/en/>

Printed in Japan 202009 IP.SIN

The image shows the Komatsu logo, which consists of the word "KOMATSU" in a bold, blue, sans-serif font. A registered trademark symbol (®) is located to the upper right of the letter "U". The logo is positioned in the top-left corner of a large, empty rectangular box that occupies the lower half of the page.

CEN00373-05

Materials and specifications are subject to change without notice
KOMATSU is a trademark of Komatsu Ltd. Japan