

# KOMATSU®

## GD825A-2

**GD**  
**825**

#### HORSEPOWER

Gross: 223 kW 298 HP / 2100 min<sup>-1</sup>

Net: 209 kW 280 HP / 2100 min<sup>-1</sup>

#### OPERATING WEIGHT

31655 kg

#### BLADE LENGTH

4.88 m



Photos may include optional equipment.

# **WALK-AROUND**







### **PERFORMANCE**

- ▮ Blade Stability
- ▮ Long Wheelbase & Short Turning Radius

### **EASY OPERATION**

- ▮ Optimized Hydraulic System
- ▮ Rear Frame-mounted Cabin

### **RELIABILITY**

- ▮ Increase Uptime, Reduce Downtime

### **SERVICEABILITY**

- ▮ Electronic Display and Monitoring System
- ▮ Easy Maintenance Design
- ▮ Elevating Cab

### **COMFORT**

- ▮ Excellent Visibility
- ▮ Spacious Interior

#### **GD825A-2**

<b>HORSEPOWER</b>	Gross:	223 kW 298 HP/2100 min <sup>-1</sup>
	Net:	209 kW 284 HP/2100 min <sup>-1</sup>
<b>OPERATING WEIGHT</b>		31655 kg
<b>BLADE LENGTH</b>		4.88 m

# PERFORMANCE



## Blade Stability

Weight distribution on the front and rear wheels is well balanced, particularly the large weight on the front reduces side slipping and keeps stability while carrying materials. The GD825A-2 also features a large blade down pressure thanks to optimal weight distribution, that enables the operator to easily penetrate compacted haul roads, ensuring efficient grading operation with fewer passes.

## Long Wheelbase & Short Turning Radius

The long wheelbase enables high leveling performance with a long blade and easier to set the blade position. Long wheelbase also contributes to expanding blade reach in combination with large articulation angle. Additionally the minimum turning radius still short with wide steering angle, serves high maneuverability.





**EASY OPERATION****Optimized Hydraulic System****Control valve**

Komatsu Multifunctional Control Valve with Closed Load Sensing System (CLSS) Hydraulic System enable the constant cylinder speed, excellent multifunctional operation ability and fine control.

**1) Low operating effort**

Implement controls are designed to reduce operator fatigue. They feature short lever throws and effort in both directions. Properly spaced control levers and short lever throws allow the operator to use multiple controls with one hand.

**2) Balanced flow**

When the operator uses several controls at the same time, flow is proportional to ensure several implements can operate simultaneously.

**3) Constant implement speed**

Implement speed is constant regardless of engine speed because of the large pump output and proportional flow control function.

**Rear Frame-mounted Cabin**

This design enables the operator to watch the blade control easily. This cabin keeps facing to the traveling direction even during offset operation, giving the operator a natural feeling.





## Increase Uptime, Reduce Downtime

### Slip clutch circle drive

Protects the work equipment from shock load when the blade hits an obstruction. Return of the blade position, it is easily done by lever.

### Wet multiple-disc brake

This brake system is completely sealed and adjustment-free. The large braking surface provides dependable braking capability and extends life before an overhaul.

### Double seal cylinder (Blade side shift cylinder)

A double-seal design is used for the blade side shift cylinder, which is installed near the ground and possibly gets damage by dirt.

### Sealed connectors

Main harnesses and controller are connected by sealed connectors providing high reliability, water resistance, and dust resistance.

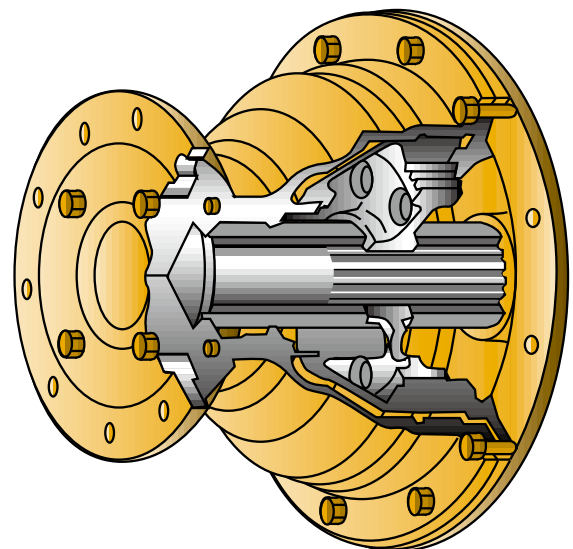



# SERVICEABILITY

## Electronic Display and Monitoring System

The electronic display and monitoring system, located directly on the steering post for excellent visibility, continuously tracks the performance of all critical operating systems and alerts the operator in the event of a system malfunction before costly damage occurs.

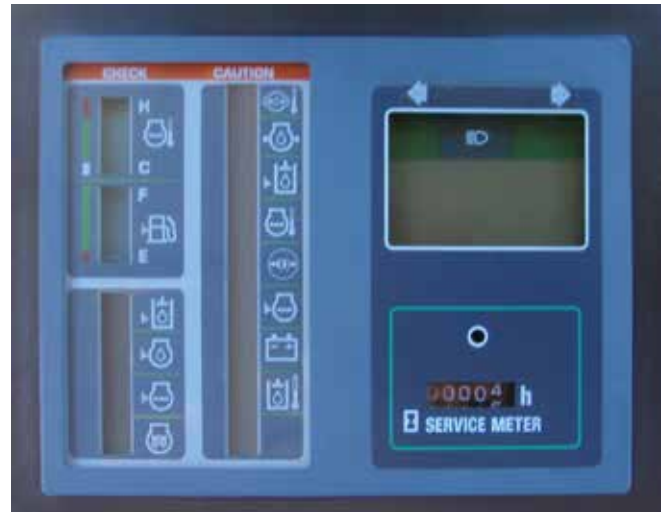

## Easy Maintenance Design

### Accessibility to service areas

- Easy and more safety refueling from the ground
- Large hinged service door serves wide inspection area
- Service meter is integrated with the machine monitor
- Distinguishable fuse panel in the cab
- Tandem oil check points is easy to access
- Spin-on filters for quick replacing
- Oil drains located near ground

### Power train components

With a modular design, you can remove the engine, transmission or final drives independently for quick service.



## Elevating Cab

Elevating the cab facilitates quick and easy maintenance of the hydraulic piping and control linkage under the cab. The cab can be raised 710 mm without disconnecting any hydraulic piping and linkage.



# COMFORT



Excellent visibility from the cab

## Excellent Visibility

Exceptional visibility by quadrangle cab with front pillar and rear layout side pillar helps increase operator confidence and productivity in all grader applications. The well positioned blade linkage provides an unobstructed view of the moldboard and front tires. The tapered engine hood provides good visibility to the rear of the machine, especially the rear ripper.





## Spacious Interior

### Suspension seat (Optional)

The suspension, fabric covered seat which is adjustable to the operator's weight is provided as optional.

The suspension seat dampens vibrations transmitted from the machine and reduces operator fatigue.

The seat features fold-up armrests and a retractable seat belt.



### Electric shift control

The electronically controlled transmission ensures smooth, light touch speed and directional changes.



### Air conditioner

Well-positioned air conditioning vents keep the operator comfortable through a wide range of outside conditions.

### Adjustable control console

The control console is adjustable backward and forward to facilitate entry and exit from the cab. The steering wheel also tilts to the operators preference.

### Adopted DC 12 V electrical outlet (Optional)

DC 12 V outlets is included in the operator's cab.

### Storage space

The cab includes built-in storage space for personal items.



### ROPS Cab

High and low profile cab is designed to ensure ROPS/FOPS (ISO 3471/ISO 3449) certification.



# WORK EQUIPMENTS



## Komatsu Genuine Work Equipment

### Moldboard

4.88 m (16 ft) moldboard is standard for GD825A-2. Optional 2 ft blade extensions for each side are available for boosting up haul road maintenance especially for soft rock mine sites.

### Ripper

Digs up hard material cannot be removed by the moldboard. This ripper can accommodate up to 7 shanks.





**KOMATSU TOTAL SUPPORT****Komatsu Total Support**

To keep your machine available and minimize operation cost when you need it, Komatsu Distributor is ready to provide variety of support before and after procuring the machine.

**Fleet recommendation**

Komatsu Distributor can study the customer's job site and provide the most optimum fleet recommendation with detailed information to meet all of your application needs when you are considering to buy new machines or replace the existing ones from Komatsu.

**Product support**

Komatsu Distributor gives the proactive support and secures the quality of the machinery that will be delivered.

**Parts availability**

Komatsu Distributor is available for emergency inquiry by the customers for genuine, quality guaranteed Komatsu parts.

**Technical support**

Komatsu product support service (Technical support) are designed to help customer. Komatsu Distributor offers a variety of effective services how much Komatsu is dedicated to the maintenance and support of Komatsu machine.

- Preventive Maintenance (PM) clinic
- Oil & Wear analysis program

**Repair & maintenance service**

Komatsu Distributor offers quality repair and maintenance service to the customer, utilizing and promoting Komatsu developed programs.

**Komatsu Reman (Remanufactured) components**

Komatsu Reman products are the result of the implementation of the Komatsu global policy which establishes and agrees to reduce the owning, operating and total Life Cycle Costs (LCC) to Komatsu's customer through high quality, prompt delivery and competitively priced in own remanufactured products (QDC).



# SPECIFICATIONS



## ENGINE

Model . . . . . Komatsu S6D140E  
 Type . . . . . Water-cooled, 4-cycle, direct injection  
 Aspiration . . . . . Turbocharged  
 Number of cylinders . . . . . 6 - 140 mm x 165 mm  
 Bore . . . . . 140 mm  
 Stroke . . . . . 165 mm  
 Piston displacement . . . . . 15.24 L  
 Gross horsepower . . . . . 223 kW 298 HP/2100 min<sup>-1</sup>  
 Net horsepower . . . . . 209 kW 280 HP/2100 min<sup>-1</sup>  
 Maximum torque . . . . . 1255 N·m 128.0 kgfm/1400 min<sup>-1</sup>  
 Torque rise . . . . . 32 %  
 Fan speed . . . . . Max. 1686 min<sup>-1</sup>  
 Air cleaner . . . . . 2-stage, dry-type  
 Electrical . . . . . 24 V with 50 A alternator  
 Battery . . . . . 2, 12 V, 200 Ah



## TRANSMISSION AND TORQUE CONVERTER

The Komatsu HYDROSHIFT® Transmission utilizes planetary gears and hydraulically actuated, force-lubricated multiple disc clutches. A single lever completes both speed shifting and direction changes. Inching pedal allows precise finishing operation and smooth machine starts. Eight forward and reverse speeds match all job requirements. Gearshift lock device prevents accidental machine starts. Engine starts only when the shift lever is set in the park position.

Travel speeds (at rated engine speed)

Gear	Forward	Reverse
1st	4.0 km/h	4.3 km/h
2nd	5.4 km/h	5.8 km/h
3rd	8.0 km/h	8.5 km/h
4th	11.5 km/h	12.2 km/h
5th	15.8 km/h	16.9 km/h
6th	21.4 km/h	22.8 km/h
7th	31.3 km/h	33.4 km/h
8th	44.9 km/h	47.9 km/h



## TANDEM DRIVE

Oscillating welded box section . . . . . 632 mm x 241 mm  
 Side wall thickness: Inner . . . . . 22 mm  
 Outer . . . . . 25 mm  
 Wheel axle spacing . . . . . 1840 mm  
 Tandem oscillation . . . . . 15° forward, 15° reverse



## FRONT AXLE

Type . . . . . Reverse Eliot type with hydraulic leaning  
 Ground clearance at pivot . . . . . 680 mm  
 Wheel lean angle, right or left . . . . . 14.5°  
 Oscillation, total . . . . . 32°



## REAR AXLE

Alloy steel, heat treated, full floating axle.



## STEERING

Full hydraulic orbit roll type steering control system with two steering cylinders are directly actuated on the knuckle arm.  
 Minimum turning radius . . . . . 8.0 m  
 Maximum steering range, right or left . . . . . 50°  
 Articulation . . . . . 25°



## BRAKES

Service brakes . . . Air-actuated, wet, multiple disc brakes on four rear wheels. Sealed for adjustment-free operation.  
 Two, crossed brake lines.  
 Parking brake . . . Mechanical, dry, disc-type, mounted on transmission output shaft. Spring-applied and air-released.



## FRAME

Front Frame Structure  
 Height . . . . . 400 mm  
 Width . . . . . 350 mm  
 Side . . . . . 25 mm, 16 mm  
 Upper, Lower . . . . . 32 mm



## DRAWBAR

Drawbar frame . . . . . 200 mm x 22 mm



## CIRCLE

Single piece rolled ring forging. Four circle support shoes with replaceable wear surface. Circle teeth hardened on front 180° of circle.  
 Diameter (outside) . . . . . 1775 mm  
 Circle reversing control hydraulic rotation . . . . . 360°



## MOLDBOARD

Dimensions . . . . . 4878 mm x 850 mm x 25 mm  
 Arc radius . . . . . 414 mm  
 Cutting edge . . . . . 254 mm x 25 mm  
 Blade pull . . . . . 18300 kgf  
 Blade down pressure . . . . . 15420 kgf





**BLADE RANGE**

Circle center shift:

Right	1350 mm
Left	1200 mm

Moldboard side shift:

Right	1790 mm
Left	1790 mm

Maximum shoulder reach

Right	2500 mm
Left	2400 mm

Maximum lift . . . . . 540 mm

Maximum cutting depth . . . . . 1200 mm

Maximum blade angle, right or left . . . . . 90°

Blade tip angle . . . . . 49° forward, 5° backward



**RIPPER (OPTIONAL)**

Ripping depth, maximum	480 mm
Ripper shank holders	7
Ripper shank holder spacing	475 mm
Penetration force	16000 kgf
Machine length increase, beam raised	894 mm



**HYDRAULICS**

One variable-capacity piston pump powers the work equipment and steering system.

Output	276 L/min
Standby pressure	1.0 MPa 10 kgf/cm <sup>2</sup>
Maximum system pressure	24.5 MPa 250 kgf/cm <sup>2</sup>



**INSTRUMENT**

Gauges: Service meter, air pressure, coolant temperature, fuel level, speedometer.

Warning lights/indicator: Dust indicator, blade bank pin retract indicator, final-drive oil temperature, engine oil pressure, coolant level, coolant temperature, air pressure, alternator changing, engine oil level, hydraulic oil level, engine preheating.



**CAPACITIES (REFILLING)**

Fuel tank	500 L
Cooling system	78.5 L
Crank case	38 L
Transmission	35 L
Final drive	63 L
Tandem housing	190 L
Hydraulic system	140 L
Circle reverse housing	16 L



**OPERATING WEIGHT (APPROXIMATE)**

Operating weight includes full fuel tank, lubricants, coolant, hydraulic equipment, operator, 4878 mm blade, 23.50-25-12pr (L-3) tires, ROPS cab, Ripper, Push plate.

Total	31655 kg
On rear wheels	22875 kg
On front wheels	8780 kg



## DIMENSIONS

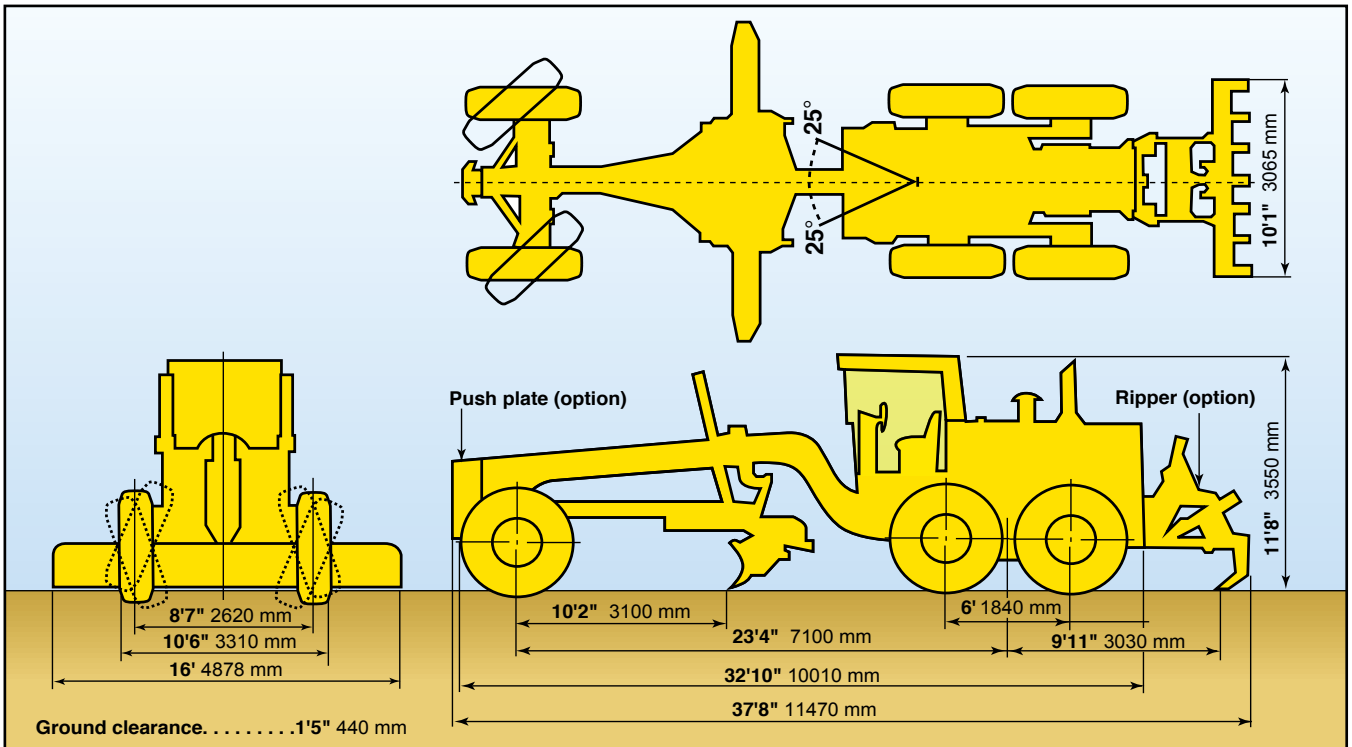

## WHEELS, FRONT AND REAR

Tire	Rim size	Rim structure
23.5-25	19.5"	Multi-piece
23.5R25	19.5"	Multi-piece



**STANDARD EQUIPMENT****Engine and Related Items**

- Air compressor (with air drier)
- Corrosion resistor
- Double element air cleaner and dust indicator
- Engine : Komatsu S6D140E, turbocharged and water cooled, 280 HP net horsepower
- Hand throttle
- Hood-sides for engine compartment
- Precleaner

**Electrical Systems**

- Alarm, back-up
- Alternator, 50 A/24 V
- Horn, electric
- Indicators, blade bank pin retract indicator, final-drive oil temperature, engine oil pressure, coolant level, coolant temperature, air pressure, alternator changing, engine oil level, hydraulic oil level, engine preheating
- Lights, back-up and headlights
- Speed meter
- Work lamps, front (4), rear (2)
- 2 x 12 V/200 Ah batteries

**Operator Environment**

- Console, adjustable with instrument panel
- Dome light, cab
- Floor mat, low noise
- Mirrors: interior cab, right and left exterior mirrors
- Seat, vinyl with seat belt

**Power Train**

- Axle, rear full floating, planetary type
- Brake, parking, spring applied, air release, disc type
- Differential lock/unlock
- Hydroshift transmission
- Service brakes, air actuated wet disk

**Work Equipment and Hydraulics**

- Circle, drawbar mounted, 360° rotation hydraulic blade lift and circle side shift
- Circle slip clutch
- Hydraulic system, closed center, load sensing
- Maximum moldboard angle position 90° right & left
- Moldboard: 4878 mm x 850 mm x 25 mm with replaceable side edges, through hardened cutting edges 254 mm x 25 mm, hydraulic blade shift and hydraulic tilt with anti-drift check valves.

- Steering, full hydraulic with tilt steering wheel plus leaning front wheels and frame articulation with anti-drift check valves
- 9 section hydraulic control valve

**Other Standard Equipment**

- Front weight
- Fuel tank, ground level access
- Painting, Komatsu standard color scheme
- Steps and handrails, rear, right and left side
- Vandalism protection includes lockable access to fuel tank and engine side covers

**OPTIONAL EQUIPMENT**

- 203 mm x 19 mm curved cutting edge
- 2 x 12 V/220 Ah batteries
- Accumulators, anti-shock for blade lift
- Air conditioner (R134a)
- AM/FM radio
- Alternator 75 A/24 V
- Auxiliary steering
- Blade extension, 2" , LH and RH
- Blade lift float detent style, LH and RH
- Cab: low or high profile enclosed ROPS/ FOPS (ISO 3471/ISO 3449) with safety tinted glass windows, front wiper and washer
- Cab mount work lamps (4)
- Cab pressurizer
- Cold area arrangement (-30°C)
- DC 12 V power port
- Engine oil pan and coolant heater
- Fire extinguisher
- General toolkit
- Heater and defrosters
- High altitude arrangement
- Lights, stop, tail and directional
- Provision for fast fuel system
- Pusher plate
- Ripper assembly, rear mounted
- Transmission underguard
- Vandalism protection, lockable access to hydraulic oil filler cap and radiator cap
- Washer, rear
- Wipers, doors and rear

<https://home.komatsu/en/>

Printed in Japan 202002 IP.AD

**KOMATSU**<sup>®</sup>

CEN00833-02

Materials and specifications are subject to change without notice.  
**KOMATSU** is a trademark of Komatsu Ltd. Japan.